

# Dell EMC PowerEdge R6415

## Installation and Service Manual

## Notes, cautions, and warnings

 **NOTE:** A NOTE indicates important information that helps you make better use of your product.

 **CAUTION:** A CAUTION indicates either potential damage to hardware or loss of data and tells you how to avoid the problem.

 **WARNING:** A WARNING indicates a potential for property damage, personal injury, or death.

**Copyright © 2017 Dell Inc. or its subsidiaries. All rights reserved.** Dell, EMC, and other trademarks are trademarks of Dell Inc. or its subsidiaries. Other trademarks may be trademarks of their respective owners.

# Contents

<b>1 Dell EMC PowerEdge R6415 overview.....</b>	<b>7</b>
Supported configurations for the PowerEdge R6415 system.....	7
Front view of the system.....	8
Left control panel view.....	10
Right control panel view.....	13
LCD panel.....	14
Drive indicator codes.....	15
Back view of the system.....	16
NIC indicator codes.....	18
Power supply unit indicator codes.....	18
Cabled power supply unit indicator codes.....	19
Locating the Service Tag of your system.....	20
<b>2 Documentation resources.....</b>	<b>21</b>
<b>3 Technical specifications.....</b>	<b>23</b>
System dimensions.....	24
Chassis weight.....	24
Processor specifications.....	25
PSU specifications.....	25
System battery specifications.....	25
Expansion bus specifications.....	25
Memory specifications.....	25
Drive specifications.....	26
Drives.....	26
Ports and connectors specifications.....	26
USB ports.....	26
NIC ports.....	26
Serial connector.....	27
VGA ports.....	27
Internal Dual SD Module and vFlash module.....	27
Video specifications.....	27
Environmental specifications.....	28
Particulate and gaseous contamination specifications .....	29
Standard operating temperature.....	30
Expanded operating temperature.....	30
Thermal restriction matrix.....	31
<b>4 Initial system setup and configuration.....</b>	<b>32</b>
Setting up your system.....	32
iDRAC configuration.....	32
Options to set up iDRAC IP address.....	32

Log in to iDRAC.....	33
Options to install the operating system.....	33
Methods to download firmware and drivers.....	33
Downloading drivers and firmware.....	34
<b>5 Pre-operating system management applications.....</b>	<b>35</b>
Options to manage the pre-operating system applications.....	35
System Setup.....	35
Viewing System Setup.....	35
System Setup details.....	36
System BIOS.....	36
iDRAC Settings utility.....	53
Device Settings.....	54
Dell Lifecycle Controller.....	54
Embedded system management.....	54
Boot Manager.....	54
Viewing Boot Manager.....	54
Boot Manager main menu.....	54
One-shot BIOS boot menu.....	55
System Utilities.....	55
PXE boot.....	55
<b>6 Installing and removing system components.....</b>	<b>56</b>
Safety instructions.....	56
Before working inside your system.....	56
After working inside your system.....	56
Recommended tools.....	57
Optional front bezel.....	57
Removing the front bezel.....	57
Installing the front bezel.....	58
System cover.....	59
Removing the system cover.....	59
Installing the system cover.....	60
Backplane cover.....	61
Removing the backplane cover.....	61
Installing the backplane cover.....	62
Inside the system.....	63
Air shroud.....	64
Removing the air shroud.....	64
Installing the air shroud.....	65
Cooling fans.....	66
Removing a cooling fan.....	66
Installing a cooling fan.....	67
Intrusion switch.....	68
Removing the intrusion switch.....	68
Installing the intrusion switch.....	68

Drives.....	69
Removing a drive blank.....	69
Installing a drive blank.....	70
Removing a drive carrier.....	70
Installing a drive carrier.....	71
Removing the drive from the drive carrier.....	72
Installing a drive into the drive carrier.....	73
System memory.....	74
General memory module installation guidelines.....	75
Mode-specific guidelines.....	76
Removing a memory module.....	76
Installing a memory module.....	77
Processors and heat sinks.....	78
Removing a heat sink.....	78
Removing the processor.....	79
Installing the processor.....	82
Installing the heat sink.....	85
Expansion cards and expansion card risers.....	86
Expansion card installation guidelines.....	87
Removing the expansion card risers.....	89
Installing the expansion card risers.....	90
Removing expansion card from the expansion card riser.....	91
Installing an expansion card into the expansion card riser.....	93
Optional IDSDM or vFlash module.....	95
Removing the MicroSD card.....	95
Installing the MicroSD card.....	95
Removing the IDSDM or vFlash module.....	96
Installing the IDSDM or vFlash module.....	96
LOM riser card.....	97
Removing the LOM riser card.....	97
Installing the LOM riser card.....	99
Mini PERC card.....	101
Removing the mini PERC card.....	101
Installing the mini PERC card.....	102
Drive backplane.....	103
Removing the backplane .....	104
Installing the drive backplane.....	105
Cable routing.....	107
System battery.....	110
Replacing the system battery.....	110
Optional internal USB memory key.....	111
Replacing the internal USB memory key.....	112
Optical drive (optional).....	112
Removing the optical drive.....	112
Installing an optical drive.....	113

Power supply units.....	114
Hot spare feature.....	114
Removing a power supply unit blank.....	114
Installing a power supply unit blank.....	115
Removing a hot swappable power supply unit.....	115
Installing a hot swappable power supply unit.....	116
Removing a cabled power supply unit.....	117
Installing a cabled power supply unit.....	118
Power interposer board.....	119
Removing the power interposer board.....	119
Installing the power interposer board.....	119
Control panel.....	120
Removing the left control panel.....	120
Installing the left control panel.....	121
Removing the right control panel.....	122
Installing the right control panel.....	123
System board.....	125
Removing the system board.....	125
Installing the system board.....	126
Restoring the Service Tag using Easy Restore.....	128
Manually update the Service Tag.....	128
Trusted Platform Module.....	128
Replacing the Trusted Platform Module.....	128
Initializing TPM for BitLocker users.....	129
<b>7 Using system diagnostics.....</b>	<b>130</b>
Dell Embedded System Diagnostics.....	130
Running the Embedded System Diagnostics from Boot Manager.....	130
Running the Embedded System Diagnostics from the Dell Lifecycle Controller.....	130
System diagnostic controls.....	131
<b>8 Jumpers and connectors .....</b>	<b>132</b>
System board jumpers and connectors.....	133
System board jumper settings.....	134
Disabling forgotten password.....	135
<b>9 Getting help.....</b>	<b>136</b>
Contacting Dell.....	136
Documentation feedback.....	136
Accessing system information by using QRL.....	136
Quick Resource Locator for R6415.....	137
Receiving automated support with SupportAssist .....	137

# Dell EMC PowerEdge R6415 overview

The PowerEdge R6415 is a 1U, single socket rack system and support these configurations:

- up to 4 x 3.5 inch or 8 x 2.5 inch SAS, Nearline SAS, or SATA drives or up to 10 x 2.5 inch NVMe drives
- One AMD Naples socket SP3 compatible processor
- 16 DIMM slots
- Two redundant power supply units (PSU) or single cabled PSU

**⚠ WARNING: Hot swap for NVMe drives is currently not supported for your system. Ensure that you turn off the system before installing or removing NVMe drives.**

**📌 NOTE: All instances of SAS, SATA hard drives, and SSDs are referred to as drives in this document, unless specified otherwise.**

Topics:

- [Supported configurations for the PowerEdge R6415 system](#)
- [Front view of the system](#)
- [Back view of the system](#)
- [Locating the Service Tag of your system](#)

## Supported configurations for the PowerEdge R6415 system

The Dell EMC PowerEdge R6415 system supports the following configurations:

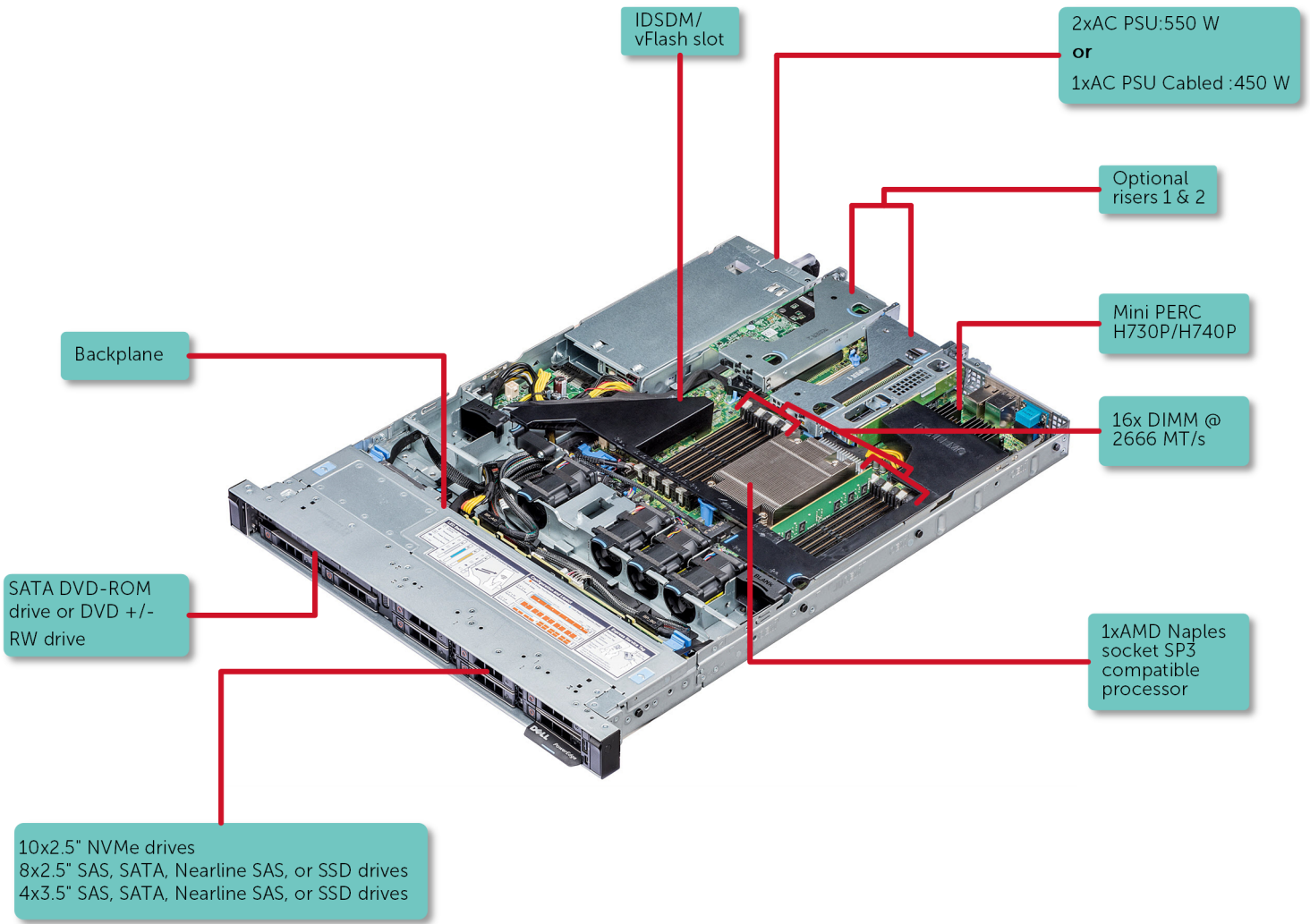

Figure 1. Supported configurations for a PowerEdge R6415

## Front view of the system

The front view displays the features available on the front of the system.

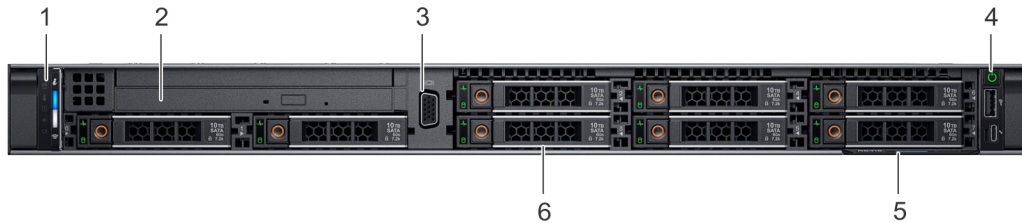

Figure 2. Front view of 8 x 2.5 inch drive system



Figure 3. Front view of 4 x 3.5 inch drive system



Figure 4. Front view of 10 x 2.5 inch drive system

Table 1. Features available on the front of the system

Item	Ports, panels, and slots	Icon	Description
1	Left control panel	N/A	Contains the system health, system ID, status LED, and the iDRAC Quick Sync 2 (wireless) indicator.
<p><b>NOTE:</b> The iDRAC Quick Sync 2 indicator is available only on certain configurations.</p> <ul style="list-style-type: none"> <li>Status LED: Enables you to identify any failed hardware components. There are up to five status LEDs and an overall system health LED (Chassis health and system ID) bar. For more information, see the Status LED indicators section.</li> <li>Quick Sync 2 (wireless): Indicates a Quick Sync enabled system. The Quick Sync feature is optional. This feature allows management of the system by using mobile devices. This feature aggregates hardware or firmware inventory and various system level diagnostic and error information that can be used in troubleshooting the system. For more information, see the Integrated Dell Remote Access Controller User's Guide at <a href="http://Dell.com/idracmanuals">Dell.com/idracmanuals</a>.</li> </ul>			
2	Optical drive (optional)	N/A	One optional slim SATA DVD-ROM drive or DVD+/-RW drive.
3	VGA port		Enables you to connect a display device to the system. For more information, see the <a href="#">Technical specifications</a> section.
4	Right control panel	N/A	Contains the power button, USB port, iDRAC Direct micro port, and the iDRAC Direct status LED.
5	Information tag		The Information Tag is a slide-out label panel that contains system information such as Service Tag, NIC, MAC address, and so on. If you have opted for the secure default access to iDRAC, the Information tag also contains the iDRAC secure default password.
6	Drive slots [3.5 inch or 2.5 inch drives]	N/A	Enables you to install drives that are supported on your system. For more information about drives, see the <a href="#">Technical specifications</a> section.

## Left control panel view

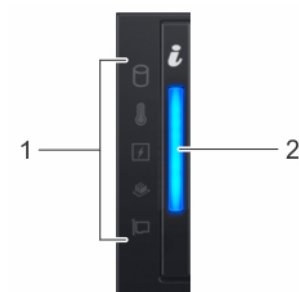

Figure 5. Left control panel without optional iDRAC Quick Sync 2.0 indicator

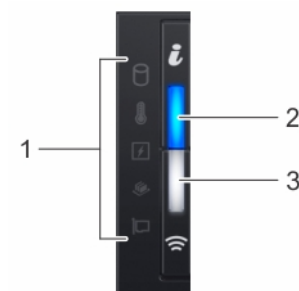

Figure 6. Left control panel with optional iDRAC Quick Sync 2.0 indicator





Table 2. Left control panel

Item	Indicator, button, or connector	Icon	Description
1	Status LED indicators	N/A	Indicate the status of the system. For more information, see the Status LED indicators section.
2	System health and system ID indicator		Indicates the system health. For more information, see the System health and system ID indicator codes section.
3	iDRAC Quick Sync 2 wireless indicator (optional)		Indicates if the iDRAC Quick Sync 2 wireless option is activated. The Quick Sync 2 feature allows management of the system using mobile devices. This feature aggregates hardware/firmware inventory and various system level diagnostic/error information that can be used in troubleshooting the system. You can access system inventory, Dell Lifecycle Controller logs or system logs, system health status, and also configure iDRAC, BIOS, and networking parameters. You can also launch the virtual Keyboard, Video, and Mouse (KVM) viewer and virtual Kernel based Virtual Machine (KVM), on a supported mobile device. For more information, see the Integrated Dell Remote Access Controller User's Guide at <a href="https://www.dell.com/support/manuals">Dell.com/idracmanuals</a> .

## Status LED indicators

**NOTE:** The indicators display solid amber if any error occurs.

**Table 3. Status LED indicators and descriptions**

Icon	Description	Condition	Corrective action
	Drive indicator	The indicator turns solid amber if there is a drive error.	<ul style="list-style-type: none"> <li>Check the System Event Log to determine if the drive has an error.</li> <li>Run the appropriate Online Diagnostics test. Restart the system and run embedded diagnostics (ePSA).</li> <li>If the drives are configured in a RAID array, restart the system, and enter the host adapter configuration utility program.</li> </ul>
	Temperature indicator	The indicator turns solid amber if the system experiences a thermal error (for example, the ambient temperature is out of range or there is a fan failure).	<p>Ensure that none of the following conditions exist:</p> <ul style="list-style-type: none"> <li>A cooling fan has been removed or has failed.</li> <li>System cover, air shroud, memory module blank, or back filler bracket is removed.</li> <li>Ambient temperature is too high.</li> <li>External airflow is obstructed.</li> </ul> <p>If the problem persists, see the <a href="#">Getting help</a> section.</p>
	Electrical indicator	The indicator turns solid amber if the system experiences an electrical error (for example, voltage out of range, or a failed power supply unit (PSU) or voltage regulator).	<p>Check the System Event Log or system messages for the specific issue. If it is due to a problem with the PSU, check the LED on the PSU. Reseat the PSU.</p> <p>If the problem persists, see the <a href="#">Getting help</a> section.</p>
	Memory indicator	The indicator turns solid amber if a memory error occurs.	<p>Check the System Event Log or system messages for the location of the failed memory. Reseat the memory module.</p> <p>If the problem persists, see the <a href="#">Getting help</a> section.</p>
	PCIe indicator	The indicator turns solid amber if a PCIe card experiences an error.	<p>Restart the system. Update any required drivers for the PCIe card. Reinstall the card.</p> <p>If the problem persists, see the <a href="#">Getting help</a> section.</p>

**NOTE:** For more information about the supported PCIe cards, see the [Getting help](#) section.

## System health and system ID indicator codes

The system health and system ID indicator is located on the left control panel of your system.



**Figure 7. System health and system ID indicators**

**Table 4. System health and system ID indicator codes**

System health and system ID indicator code	Condition
Solid blue	Indicates that the system is turned on, system is healthy, and system ID mode is not active. Press the system health and system ID button to switch to system ID mode.
Blinking blue	Indicates that the system ID mode is active. Press the system health and system ID button to switch to system health mode.
Solid amber	Indicates that the system is in fail-safe mode. If the problem persists, see the Getting help section.
Blinking amber	Indicates that the system is experiencing a fault. Check the System Event Log or the LCD panel, if available on the bezel, for specific error message. For more information about error messages, see the <i>Dell Event and Error Messages Reference Guide</i> at <a href="http://Dell.com/openmanagemanuals">Dell.com/openmanagemanuals</a> > <b>OpenManage software</b> .

## iDRAC Quick Sync 2 indicator codes

iDRAC Quick Sync 2 module (optional) is located on the left control panel of your system.



**Figure 8. iDRAC Quick Sync 2 indicators**

**Table 5. iDRAC Quick Sync 2 indicators and descriptions**

iDRAC Quick Sync 2 indicator code	Condition	Corrective action
Off (default state)	Indicates that the iDRAC Quick Sync 2 feature is turned off. Press the iDRAC Quick Sync 2 button to turn on the iDRAC Quick Sync 2 feature.	If the LED fails to turn on, reseal the left control panel flex cable and check. If the problem persists, see the <a href="#">Getting help</a> section.
Solid white	Indicates that iDRAC Quick Sync 2 is ready to communicate. Press the iDRAC Quick Sync 2 button to turn off.	If the LED fails to turn off, restart the system. If the problem persists, see the <a href="#">Getting help</a> section.
Blinks white rapidly	Indicates data transfer activity.	If the problem persists, see the <a href="#">Getting help</a> section.
Blinks white slowly	Indicates that firmware update is in progress.	If the problem persists, see the <a href="#">Getting help</a> section.
Blinks white five times rapidly and then turns off	Indicates that the iDRAC Quick Sync 2 feature is disabled.	Check if iDRAC Quick Sync 2 feature is configured to be disabled by iDRAC. If the problem persists, see the <a href="#">Getting help</a> section. For more information, see <i>Integrated Dell Remote Access Controller User's Guide</i> at <a href="http://Dell.com/idracmanuals">Dell.com/idracmanuals</a> or <i>Dell OpenManage Server Administrator User's Guide</i> at <a href="http://Dell.com/openmanagemanuals">Dell.com/openmanagemanuals</a> .

iDRAC Quick Sync 2 indicator code	Condition	Corrective action
Solid amber	Indicates that the system is in fail-safe mode.	Restart the system. If the problem persists, see the <a href="#">Getting help</a> section.
Blinking amber	Indicates that the iDRAC Quick Sync 2 hardware is not responding properly.	Restart the system. If the problem persists, see the <a href="#">Getting help</a> section.

## Right control panel view

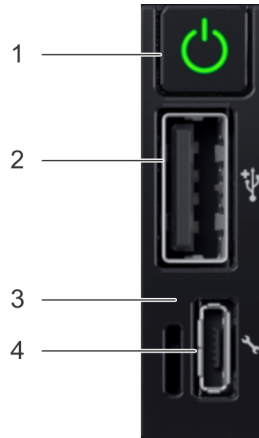



Figure 9. Right control panel

Table 6. Right control panel

Item	Indicator or button	Icon	Description
1	Power button		Indicates if the system is turned on or off. Press the power button to manually turn on or off the system.  <b>NOTE: Press the power button to gracefully shut down an ACPI-compliant operating system.</b>
2	USB port		The USB port is a 4-pin connector and, 2.0-compliant. This ports enables you to connect USB devices to the system.
3	iDRAC Direct LED	N/A	The iDRAC Direct LED indicator lights up to indicate that the iDRAC Direct port is actively connected to a device. For more information, see the iDRAC Direct LED indicator codes section.

Item	Indicator or button	Icon	Description
4	iDRAC Direct port (Micro-AB USB)		The iDRAC Direct (Micro-AB USB) port enables you to access the iDRAC Direct (Micro-AB) features. For more information, see the iDRAC User's Guide at <a href="http://Dell.com/idracmanuals">Dell.com/idracmanuals</a> .

## iDRAC Direct LED indicator codes

The iDRAC Direct LED indicator lights up to indicate that the port is connected and is being used as a part of the iDRAC subsystem.

You can configure iDRAC Direct by using a USB to micro USB (type AB) cable, which you can connect to your laptop or tablet. The following table describes iDRAC Direct activity when the iDRAC Direct port is active:

**Table 7. iDRAC Direct LED indicator codes**

iDRAC Direct LED indicator code	Condition
Solid green for two seconds	Indicates that the laptop or tablet is connected.
Flashing green (on for two seconds and off for two seconds)	Indicates that the laptop or tablet connected is recognized.
Turns off	Indicates that the laptop or tablet is unplugged.

## LCD panel

The LCD panel provides system information, status, and error messages to indicate if the system is functioning correctly or requires attention. The LCD panel can be used to configure or view the system's iDRAC IP address. For more information about error messages, see the *Dell Event and Error Messages Reference Guide* at [Dell.com/openmanagemanuals](http://Dell.com/openmanagemanuals) > **OpenManage software**.

The LCD panel is available only on the optional LCD bezel. The optional LCD bezel is hot pluggable.

The statuses and conditions of the LCD panel are outlined here:

- The LCD backlight is white during normal operating conditions.
- When the system needs attention, the LCD backlight turns amber, and displays an error code followed by descriptive text.

**NOTE:** If the system is connected to a power source and an error is detected, the LCD turns amber regardless of whether the system is turned on or off.

- When the system turns off and there are no errors, LCD enters the standby mode after five minutes of inactivity. Press any button on the LCD to turn it on.
- If the LCD panel stops responding, remove the bezel and reinstall it. If the problem persists, see the Getting help section.
- The LCD backlight remains off if LCD messaging is turned off using the iDRAC utility, the LCD panel, or other tools.

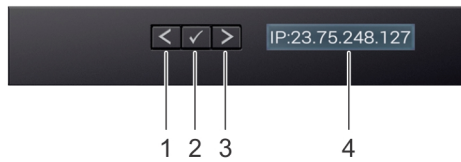

Figure 10. LCD panel features

Table 8. LCD panel features

Item	Button or display	Description
1	Left	Moves the cursor back in one-step increments.
2	Select	Selects the menu item highlighted by the cursor.
3	Right	Moves the cursor forward in one-step increments. During message scrolling: <ul style="list-style-type: none"> <li>Press and hold the right button to increase scrolling speed.</li> <li>Release the button to stop.</li> </ul>
		<p><b>NOTE:</b> The display stops scrolling when the button is released. After 45 seconds of inactivity, the display starts scrolling.</p>
4	LCD display	Displays system information, status, and error messages or iDRAC IP address.

## Drive indicator codes

Each drive carrier has an activity LED indicator and a status LED indicator. The indicators provide information about the current status of the drive. The activity LED indicator indicates whether the drive is currently in use or not. The status LED indicator indicates the power condition of the drive.

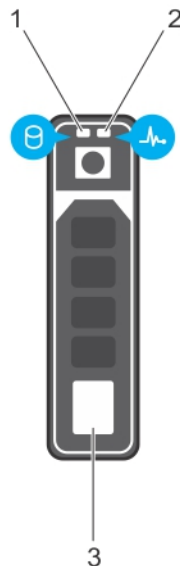

Figure 11. Drive indicators

1 Drive activity LED indicator

2 Drive status LED indicator

**NOTE:** If the drive is in the Advanced Host Controller Interface (AHCI) mode, the status LED indicator does not turn on.

**Table 9. Drive indicator codes**

Drive status indicator code	Condition
Flashes green twice per second	Identifying drive or preparing for removal.
Off	Drive ready for removal.
	<b>NOTE:</b> The drive status indicator remains off until all drives are initialized after the system is turned on. Drives are not ready for removal during this time.
Flashes green, amber, and then turns off	Predicted drive failure.
Flashes amber four times per second	Drive failed.
Flashes green slowly	Drive rebuilding.
Solid green	Drive online.
Flashes green for three seconds, amber for three seconds, and then turns off after six seconds	Rebuild stopped.

## Back view of the system

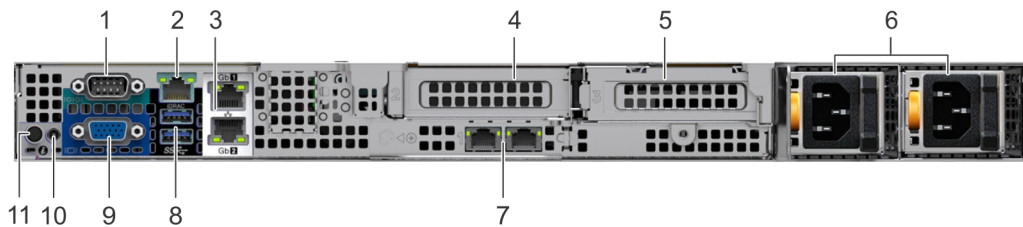





**Figure 12. Back view of the system with redundant PSU**



**Figure 13. Back view of the system with cabled PSU**

**Table 10. Back view of the system**

Item	Ports, panels, or slots	Icon	Description
1	Serial port	IOIOI	Enables you to connect a serial device to the system. For more information, see the <a href="#">Technical specifications</a> section.
2	iDRAC9 dedicated port	Wrench icon	Enables you to remotely access iDRAC. For more information, see the iDRAC User's Guide at <a href="http://Dell.com/idracmanuals">Dell.com/idracmanuals</a> .

Item	Ports, panels, or slots	Icon	Description
3	NIC ports (2)		The NIC ports that are integrated on the system board provide network connectivity. For more information about the supported configurations, see the <a href="#">Technical specifications</a> section.
4	PCIe expansion card riser 2	N/A	The expansion card riser enables you to connect PCI Express expansion cards. For more information on the expansion cards that are supported on your system, see the <a href="#">Expansion card installation guidelines</a> .
5	PCIe expansion card riser 1	N/A	The expansion card riser enables you to connect PCI Express expansion cards. For more information on the expansion cards that are supported on your system, see the <a href="#">Expansion card installation guidelines</a> .
6	Power supply units (redundant)	N/A	For more information about the PSU configurations, see the <a href="#">Technical specifications</a> section
7	LOM riser (optional)		The NIC ports that are integrated on the LAN on Motherboard (LOM) riser provide network connectivity. For more information about the supported configurations, see the <a href="#">Technical specifications</a> section.
8	USB 3.0 port (2)		These USB ports support USB 3.0.
9	VGA port		Enables you to connect a display device to the system. For more information, see the <a href="#">Technical specifications</a> section.
10	CMA power port	N/A	The Cable Management Arm (CMA) power port enables you to connect to the CMA.
11	System identification button		<p>Press the system ID button:</p> <ul style="list-style-type: none"> <li>• To locate a particular system within a rack.</li> <li>• To turn the system ID on or off.</li> </ul> <p>To reset iDRAC, press and hold the button for more than 15 seconds.</p> <p><b>i NOTE:</b></p> <ul style="list-style-type: none"> <li>• To reset iDRAC using system ID, ensure that the system ID button is enabled in the iDRAC setup.</li> <li>• If the system stops responding during POST, press and hold the system ID button (for more than five seconds) to enter the BIOS progress mode.</li> </ul>
12	Power supply unit (cabled)	N/A	For more information about the PSU configurations, see the <a href="#">Technical specifications</a> section

## NIC indicator codes

Each NIC on the back of the system has indicators that provide information about the activity and link status. The activity LED indicator indicates if data is flowing through the NIC, and the link LED indicator indicates the speed of the connected network.

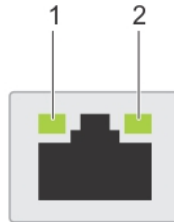

Figure 14. NIC indicator codes

- 1 link LED indicator
- 2 activity LED indicator

Table 11. NIC indicator codes

Status	Condition
Link and activity indicators are off	The NIC is not connected to the network.
Link indicator is green and activity indicator is blinking green	The NIC is connected to a valid network at its maximum port speed and data is being sent or received.
Link indicator is amber and activity indicator is blinking green	The NIC is connected to a valid network at less than its maximum port speed and data is being sent or received.
Link indicator is green and activity indicator is off	The NIC is connected to a valid network at its maximum port speed and data is not being sent or received.
Link indicator is amber and activity indicator is off	The NIC is connected to a valid network at less than its maximum port speed and data is not being sent or received.
Link indicator is blinking green and activity is off	NIC identify is enabled through the NIC configuration utility.

## Power supply unit indicator codes

AC power supply units (PSUs) have an illuminated translucent handle that serves as an indicator. The indicator shows whether power is present or if a power fault has occurred.



Figure 15. PSU status indicator

- 1 PSU status indicator/handle

**Table 12. PSU status indicator codes**

Power indicator codes	Condition
Green	A valid power source is connected to the PSU and the PSU is operational.
Blinking amber	Indicates a problem with the PSU.
Not illuminated	Power is not connected to the PSU.
Blinking green	When the firmware of the PSU is being updated, the PSU handle blinks green. <div style="border-left: 2px solid orange; padding-left: 10px; margin-top: 5px;"> <p><b>CAUTION:</b> Do not disconnect the power cord or unplug the PSU when updating firmware. If firmware update is interrupted, the PSUs do not function.</p> </div>
Blinking green and turns off	When hot-plugging a PSU, the PSU handle blinks green five times at a rate of 4 Hz and turns off. This indicates a PSU mismatch with respect to efficiency, feature set, health status, or supported voltage. <div style="border-left: 2px solid orange; padding-left: 10px; margin-top: 5px;"> <p><b>CAUTION:</b> If two PSUs are installed, both the PSUs must have the same type of label; for example, Extended Power Performance (EPP) label. Mixing PSUs from previous generations of PowerEdge servers is not supported, even if the PSUs have the same power rating. This results in a PSU mismatch condition or failure to turn the system on.</p> </div> <div style="border-left: 2px solid orange; padding-left: 10px; margin-top: 5px;"> <p><b>CAUTION:</b> When correcting a PSU mismatch, replace only the PSU with the blinking indicator. Swapping the PSU to make a matched pair can result in an error condition and unexpected system shutdown. To change from a high output configuration to a low output configuration or vice versa, you must turn off the system.</p> </div> <div style="border-left: 2px solid orange; padding-left: 10px; margin-top: 5px;"> <p><b>CAUTION:</b> AC PSUs support both 240 V and 120 V input voltages. When two identical PSUs receive different input voltages, they can output different wattages, and trigger a mismatch.</p> </div> <div style="border-left: 2px solid orange; padding-left: 10px; margin-top: 5px;"> <p><b>CAUTION:</b> If two PSUs are used, they must be of the same type and have the same maximum output power.</p> </div>

## Cabled power supply unit indicator codes

Press the self-diagnostic button to perform a quick health check on the cabled power supply unit (PSU) of the system.

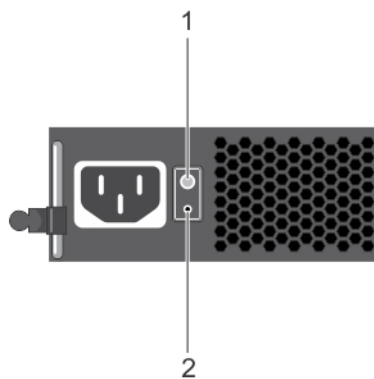

**Figure 16. Cabled PSU status indicator and self-diagnostic button**

1 self-diagnostic button

2 AC PSU status indicator

**Table 13. Cabled AC PSU status indicator**

Power Indicator Pattern	Condition
Not lit	Power is not connected or PSU is faulty.
Green	A valid power source is connected to the PSU and the PSU is operational.

## Locating the Service Tag of your system

You can identify your system using the unique Express Service Code and Service Tag. Pull out the information tag in front of the system to view the Express Service Code and Service Tag. Alternatively, the information may be on a sticker on the chassis of the system. The mini Enterprise Service Tag (EST) is found on the back of the system. This information is used by Dell to route support calls to the appropriate personnel.

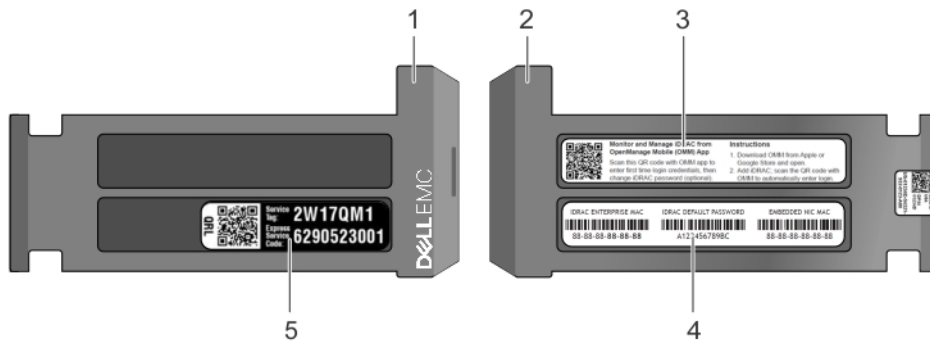

**Figure 17. Locating Service Tag of your system**

- 1 Information tag (front view)
- 2 Information tag (back view)
- 3 OpenManage Mobile (OMM) label (optional)
- 4 iDRAC MAC address and iDRAC secure password label
- 5 Service Tag

## Documentation resources

This section provides information about the documentation resources for your system.

**Table 14. Additional documentation resources for your system**

Task	Document	Location
Setting up your system	For more information about installing and securing the system into a rack, see the rack documentation included with your rack solution.	<a href="https://dell.com/poweredge/manuals">Dell.com/poweredgemanuals</a>
	For information about setting up and turning on the system, see the <i>Getting Started Guide</i> document that is shipped with your system.	<a href="https://dell.com/poweredge/manuals">Dell.com/poweredgemanuals</a>
Configuring your system	For information about the iDRAC features, configuring and logging in to iDRAC, and managing your system remotely, see the Integrated Dell Remote Access Controller User's Guide.	<a href="https://dell.com/idrac/manuals">Dell.com/idracmanuals</a>
	For information about installing the operating system, see the operating system documentation.	<a href="https://dell.com/operatingsystem/manuals">Dell.com/operatingsystemmanuals</a>
	For information about understanding Remote Access Controller Admin (RACADM) subcommands and supported RACADM interfaces, see the RACADM Command Line Reference Guide for iDRAC.	<a href="https://dell.com/idrac/manuals">Dell.com/idracmanuals</a>
	For information about updating drivers and firmware, see the Methods to download firmware and drivers section in this document.	To download drivers: <a href="https://dell.com/support/drivers">Dell.com/support/drivers</a>
Managing your system	For information about systems management software offered by Dell, see the Dell OpenManage Systems Management Overview Guide.	<a href="https://dell.com/openmanage/manuals">Dell.com/openmanagemanuals</a>
	For information about setting up, using, and troubleshooting OpenManage, see the Dell OpenManage Server Administrator User's Guide.	<a href="https://dell.com/openmanage/manuals">Dell.com/openmanagemanuals</a>
	For information about installing, using, and troubleshooting Dell OpenManage Essentials, see the Dell OpenManage Essentials User's Guide.	<a href="https://dell.com/openmanage/manuals">Dell.com/openmanagemanuals</a>
	For information about installing and using Dell SupportAssist, see the Dell EMC SupportAssist Enterprise User's Guide.	<a href="https://dell.com/serviceability/tools">Dell.com/serviceabilitytools</a>
	For understanding the features of Dell Lifecycle Controller, see the Dell Lifecycle Controller User's Guide.	<a href="https://dell.com/idrac/manuals">Dell.com/idracmanuals</a>

Task	Document	Location
	For information about partner programs enterprise systems management, see the OpenManage Connections Enterprise Systems Management documents.	<a href="https://dell.com/openmanagemanuals">Dell.com/openmanagemanuals</a>
Working with the Dell PowerEdge RAID controllers	For information about understanding the features of the Dell PowerEdge RAID controllers (PERC), Software RAID controllers, or BOSS card and deploying the cards, see the Storage controller documentation.	<a href="https://dell.com/storagecontrollermanuals">Dell.com/storagecontrollermanuals</a>
Understanding event and error messages	For information about checking the event and error messages generated by the system firmware and agents that monitor system components, see the Dell Event and Error Messages Reference Guide.	<a href="https://dell.com/openmanagemanuals">Dell.com/openmanagemanuals</a> > <a href="#">OpenManage software</a>
Troubleshooting your system	For information about identifying and troubleshooting the PowerEdge server issues, see the Server Troubleshooting Guide.	<a href="https://dell.com/poweredgemanuals">Dell.com/poweredgemanuals</a>

# Technical specifications

The technical and environmental specifications of your system are outlined in this section.

Topics:

- System dimensions
- Chassis weight
- Processor specifications
- PSU specifications
- System battery specifications
- Expansion bus specifications
- Memory specifications
- Drive specifications
- Ports and connectors specifications
- Video specifications
- Environmental specifications

# System dimensions

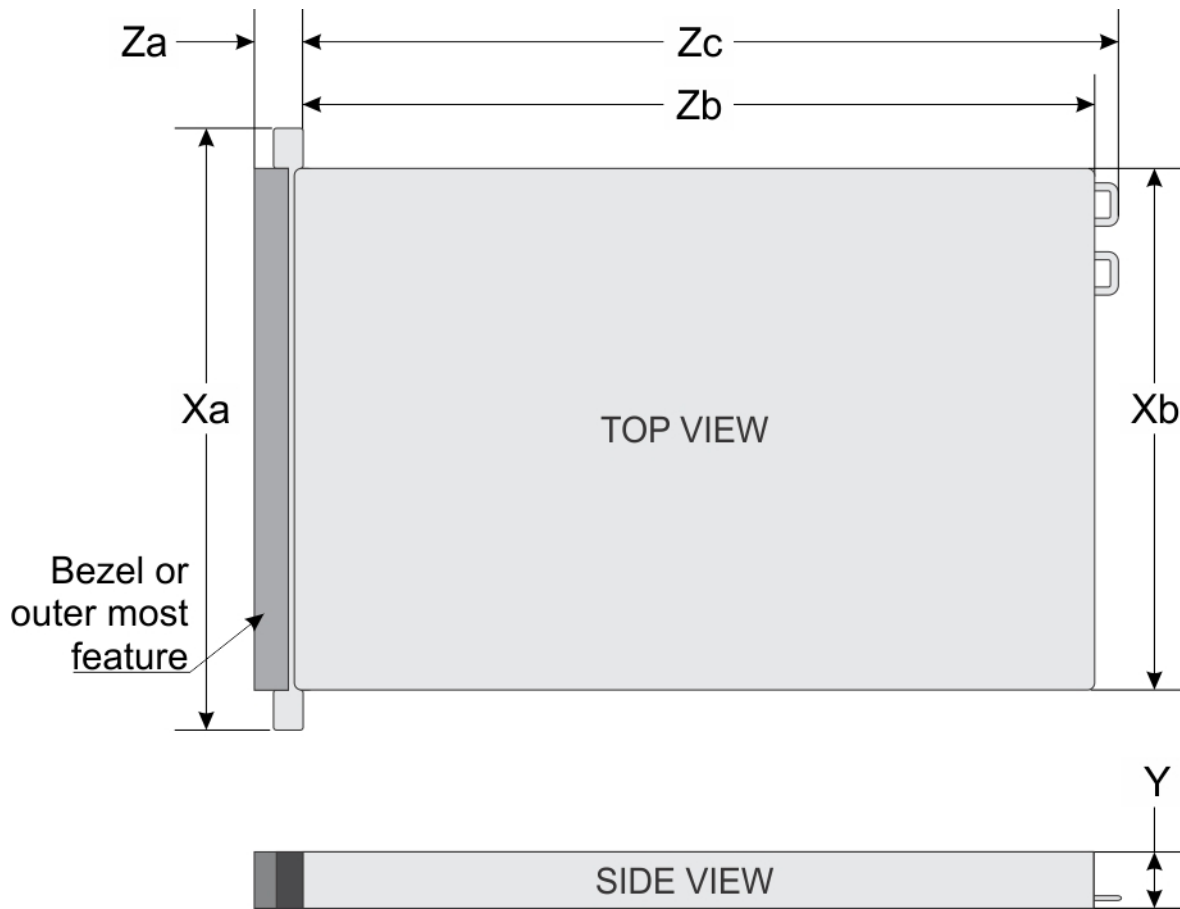

Figure 18. Dimensions of the PowerEdge R6415 system

Table 15. Dimensions of the PowerEdge R6415 system

Xa	Xb	Y	Za (with bezel)	Za (without bezel)	Zb	Zc
482.0 mm (18.97 inches)	434.0 mm (17.08 inches)	42.8 mm (3.41 inches)	35.84 mm (1.41 inches)	22 mm (0.87 inches)	x4 and x10 = 657.25 mm (25.87 inches) x8 = 606.47 (23.87 inches)	x4 and x10 = 692.62 (27.26 inches) x8 = 641.85 mm (25.26 inches)

# Chassis weight

Table 16. Chassis weight

System	Maximum weight (with all drives/SSDs)
4 x 3.5 inch drive system	16.91 kg (37.28 lb)
8 x 2.5 inch drive system	14.5 kg (34.17 lb)

System	Maximum weight (with all drives/SSDs)
10 x 2.5 inch drive system	16.01 kg (35.29 lb)

## Processor specifications

The PowerEdge R6415 system supports one AMD Naples socket SP3 compatible processor.

## PSU specifications

The PowerEdge R6415 system supports the following AC power supply units (PSUs).

**Table 17. PSU specifications**

PSU	Class	Heat dissipation (maximum)	Frequency	Voltage
550 W AC	Platinum	2107 BTU/hr	50/60 Hz	100–240 V AC, autoranging
450 W AC (cabled)	Bronze	1871 BTU/hr	50/60 Hz	100–240 V AC, autoranging

**NOTE:** Heat dissipation is calculated using the PSU wattage rating.

**NOTE:** This system is also designed to connect to the IT power systems with a phase-to-phase voltage not exceeding 230 V.

## System battery specifications

The PowerEdge R6415 system supports CR 2032 3.0-V lithium coin cell system battery.

## Expansion bus specifications

The PowerEdge R6415 system supports up to two Gen3 PCI express (PCIe) expansion cards, which need to be installed on the system board using expansion card risers. The R6415 system supports three configurations:

<b>Riser configuration</b>	Supported configuration
<b>No riser</b>	N/A
<b>Single PCIe slot riser</b>	1 x 16x Gen3 slot
<b>Dual PCIe slot riser</b>	2 x 16x Gen3 slots

## Memory specifications

The PowerEdge R6415 system supports 16 DDR4 registered DIMM (RDIMMs) slots. Supported memory bus frequencies are 2666 MT/s, 2400 MT/s, 2133 MT/s, and 1866 MT/s.

**Table 18. Memory specifications**

Memory module sockets	Memory capacity	Minimum RAM	Maximum RAM
Sixteen 288-pin	<ul style="list-style-type: none"> <li>8 GB, 16 GB, or 32 GB single rank or dual rank (RDIMMs)</li> <li>64 GB dual rank or quad rank (LRDIMMs)</li> </ul>	<ul style="list-style-type: none"> <li>8 GB with single processor</li> </ul>	<ul style="list-style-type: none"> <li>Up to 1024 GB with a single processor</li> </ul>

**NOTE:** For optimal performance, populate one DIMM per channel with DDR4-2666 memory modules on the first slot of each memory channel. The first slot of each channel can be identified as the DIMM slots with white latches. For example, 64 GB system memory capacity can be divided into 8 x 8 GB DIMM slots.

## Drive specifications

### Drives

The PowerEdge R6415 system is available in these configurations:

- Up to 4 x 3.5 inch SAS or SATA drives
- Up to 8 x 2.5 inch SAS or SATA drives
- Up to 10 x 2.5 inch NVMe drives

**WARNING:** Hot swap for NVMe drives is currently not supported for your system. Ensure that you turn off the system before installing or removing the NVMe drives.

## Ports and connectors specifications

### USB ports

The PowerEdge R6415 system supports:

The following table provides more information about the USB specifications:

**Table 19. USB specifications**

Front panel	Back panel	Internal USB
<ul style="list-style-type: none"><li>• Two USB 2.0 ports</li></ul>	<ul style="list-style-type: none"><li>• Two USB 3.0 ports</li></ul>	<ul style="list-style-type: none"><li>• One internal USB 3.0 port</li></ul>

(One AB– Micro USB 2.0 port (dedicated iDRAC Direct) + one standard USB 2.0 port)

**NOTE:** The micro USB 2.0 compliant port on the front of the system can only be used as an iDRAC Direct or a management port

### NIC ports

The PowerEdge R6415 system supports two onboard network ports accessible from the back panel, each port supports up to 1 Gbps. The system also supports LAN on Motherboard (LOM) on an optional riser card.

You can install one LOM riser card. The supported options are listed here:

- 2 x 1 Gb Base-T
- 2 x 10Gb Base-T
- 2 x 10Gb SPF+

**NOTE:**

- You can install up to four PCIe add-on NIC cards.
- For information about Linux network performance settings, see the *Linux® Network Tuning Guide for AMD EPYC™ Processor Based Servers* AMD tuning guide.

## Serial connector

The serial connector connects a serial device to the system. The PowerEdge R6415 system supports one serial connector on the back panel, which is a 9-pin connector, Data Terminal Equipment (DTE), 16550-compliant.

## VGA ports

The Video Graphic Array (VGA) port enables you to connect the system to a VGA display. The PowerEdge R6415 system supports two 15-pin VGA ports one each on the front and back panels.

## Internal Dual SD Module and vFlash module

The PowerEdge R6415 system supports two options for the Internal Dual SD Module (IDSDM) and vFlash module:

- vFlash memory card slot along with dual MicroSD cards supported on the same module
- vFlash memory card slot module

**NOTE:**

- In the IDSDM one of the MicroSD card slots is dedicated for redundancy.
- The IDSDM card provides software RAID1 support for the MicroSD cards.
- Dual MicroSD cards are not required as the module can operate with only one card but will provide no redundancy or RAID capability.

## Video specifications

The PowerEdge R6415 system supports Matrox G200eR2 graphics card with 16 MB capacity.

**Table 20. Supported video resolution options**

Resolution	Refresh rate (Hz)	Color depth (bits)
1024 x 768	60	8, 16, 32
1280 x 800	60	8, 16, 32
1280 x 1024	60	8, 16, 32
1360 x 768	60	8, 16, 32
1440 x 900	60	8, 16, 32
1600 x 900	60	8, 16, 32
1600 x 1200	60	8, 16, 32
1680 x 1050	60	8, 16, 32
1920 x 1080	60	8, 16, 32
1920 x 1200	60	8, 16, 32

# Environmental specifications

**NOTE:** For additional information about environmental measurements for specific system configurations, see [Dell.com/environmental\\_datasheets](https://www.dell.com/environmental_datasheets).

**Table 21. Temperature specifications**

Temperature	Specifications
Storage	-40°C to 65°C (-40°F to 149°F)
Continuous operation (for altitude less than 950 m or 3117 ft)	10°C to 35°C (50°F to 95°F) with no direct sunlight on the equipment.
Fresh air	For information about fresh air, see the Expanded Operating Temperature section.
Maximum temperature gradient (operating and storage)	20°C/h (68°F/h)

**Table 22. Relative humidity specifications**

Relative humidity	Specifications
Storage	5% to 95% RH with 33°C (91°F) maximum dew point. Atmosphere must be non-condensing at all times.
Operating	10% to 80% relative humidity with 29°C (84.2°F) maximum dew point.

**Table 23. Maximum vibration specifications**

Maximum vibration	Specifications
Operating	0.26 G <sub>rms</sub> at 5 Hz to 350 Hz (all operation orientations).
Storage	1.88 G <sub>rms</sub> at 10 Hz to 500 Hz for 15 min (all six sides tested).

**Table 24. Maximum shock specifications**

Maximum shock	Specifications
Operating	Six consecutively executed shock pulses in the positive and negative x, y, and z axes of 6 G for up to 11 ms.
Storage	Six consecutively executed shock pulses in the positive and negative x, y, and z axes (one pulse on each side of the system) of 71 G for up to 2 ms.

**Table 25. Maximum altitude specifications**

Maximum altitude	Specifications
Operating	3048 m (10,000 ft)
Storage	12,000 m (39,370 ft)

**Table 26. Operating temperature derating specifications**

Operating temperature derating	Specifications
Up to 35°C (95°F)	Maximum temperature is reduced by 1°C/300 m (1°F/547 ft) above 950 m (3,117 ft).
35°C to 40°C (95°F to 104°F)	Maximum temperature is reduced by 1°C/175 m (1°F/319 ft) above 950 m (3,117 ft).
40°C to 45°C (104°F to 113°F)	Maximum temperature is reduced by 1°C/125 m (1°F/228 ft) above 950 m (3,117 ft).

## Particulate and gaseous contamination specifications

The following table defines the limitations that help avoid any equipment damage or failure from particulates and gaseous contamination. If the levels of particulates or gaseous pollution exceed the specified limitations and result in equipment damage or failure, you may need to rectify the environmental conditions. Re-mediation of environmental conditions is the responsibility of the customer.

**Table 27. Particulate contamination specifications**

Particulate contamination	Specifications
Air filtration	<p>Data center air filtration as defined by ISO Class 8 per ISO 14644-1 with a 95% upper confidence limit.</p> <p><b>NOTE:</b> This condition applies to data center environments only. Air filtration requirements do not apply to IT equipment designed to be used outside a data center, in environments such as an office or factory floor.</p> <p><b>NOTE:</b> Air entering the data center must have MERV11 or MERV13 filtration.</p>
Conductive dust	<p>Air must be free of conductive dust, zinc whiskers, or other conductive particles.</p> <p><b>NOTE:</b> This condition applies to data center and non-data center environments.</p>
Corrosive dust	<ul style="list-style-type: none"> <li>Air must be free of corrosive dust.</li> <li>Residual dust present in the air must have a deliquescent point less than 60% relative humidity.</li> </ul> <p><b>NOTE:</b> This condition applies to data center and non-data center environments.</p>

**Table 28. Gaseous contamination specifications**

Gaseous contamination	Specifications
Copper coupon corrosion rate	<300 Å/month per Class G1 as defined by ANSI/ISA71.04-1985.
Silver coupon corrosion rate	<200 Å/month as defined by AHSRAE TC9.9.

**NOTE:** Maximum corrosive contaminant levels measured at ≤50% relative humidity.

# Standard operating temperature

Table 29. Standard operating temperature specifications

Standard operating temperature	Specifications
Continuous operation (for altitude less than 950 m or 3117 ft)	10°C to 35°C (50°F to 95°F) with no direct sunlight on the equipment.

# Expanded operating temperature

Table 30. Expanded operating temperature specifications

Expanded operating temperature	Specifications
Continuous operation	5°C to 35°C at 5% to 85% RH with 29°C dew point.  <b>i</b> <b>NOTE: Outside the standard operating temperature (10°C to 40°C), the system can operate continuously in temperatures as low as 5°C and as high as 40°C.</b>  For temperatures between 35°C and 40°C, de-rate maximum allowable temperature by 1°C per 175 m above 950 m (1°F per 319 ft).
≤ 1% of annual operating hours	–5°C to 45°C at 5% to 90% RH with 29°C dew point.  <b>i</b> <b>NOTE: Outside the standard operating temperature (10°C to 40°C), the system can operate down to –5°C or up to 45°C for a maximum of 1% of its annual operating hours.</b>  For temperatures between 40°C and 45°C, de-rate maximum allowable temperature by 1°C per 125 m above 950 m (1°F per 228 ft).

**i** **NOTE: When operating in the expanded temperature range, system performance may be impacted.**

**i** **NOTE: When operating in the expanded temperature range, ambient temperature warnings may be reported on the bezel's LCD panel and in the System Event Log.**

# Expanded operating temperature restrictions

- Do not perform a cold startup below 5°C.
- The operating temperature specified is for a maximum altitude of 3050 m (10,000 ft).
- Redundant power supply configuration is required.
- Cabled power supply unit is not supported.
- Non-Dell qualified peripheral cards and/or peripheral cards greater than 25 W are not supported.
- Processors that consume more than 180 W are not supported.

# Thermal restriction matrix

**Table 31. Thermal restriction matrix for R6415**

Storage configuration			4 x 3.5 inch drives	8 x 2.5 inch drives	10 x 2.5 inch drives (NVMe)
Fan type			Standard fan	Standard fan	Standard fan
CPU heat sink type			1U heat sink	1U heat sink	1U heat sink
Processor number	TDP (W)	Core count	Ambient = 35°C	Ambient = 35°C	Ambient = 30°C
AMD 7601	180W	32	Yes	Yes	Yes
AMD 7551	180W	32	Yes	Yes	Yes
AMD 7551P	180W	32	Yes	Yes	Yes
AMD 7501	155W	32	Yes	Yes	Yes
AMD 7451	180W	24	Yes	Yes	Yes
AMD 7401	155W	24	Yes	Yes	Yes
AMD 7401P	155W	24	Yes	Yes	Yes
AMD 7351	155W	16	Yes	Yes	Yes
AMD7351P	155W	32	Yes	Yes	Yes
AMD7301	155W	16	Yes	Yes	Yes
AMD 7251	120W	8	Yes	Yes	Yes
AMD 7281	155W	16	Yes	Yes	Yes

# Initial system setup and configuration

## Setting up your system

Complete the following steps to set up your system:

- 1 Unpack the system.
- 2 Install the system into the rack. For more information about installing the system into the rack, see the *Rail Installation Guide* at [Dell.com/poweredgemanuals](http://Dell.com/poweredgemanuals).
- 3 Connect the peripherals to the system.
- 4 Connect the system to its electrical outlet.
- 5 Turn the system on by pressing the power button or by using iDRAC.
- 6 Turn on the attached peripherals.

For more information about setting up your system, see the *Getting Started Guide* that shipped with your system.

### Related link

[iDRAC configuration](#)

[Options to set up iDRAC IP address](#)

## iDRAC configuration

The Integrated Dell Remote Access Controller (iDRAC) is designed to make system administrators more productive and improve the overall availability of Dell systems. iDRAC alerts administrators to system issues, helps them perform remote system management, and reduces the need for physical access to the system.

## Options to set up iDRAC IP address

You must configure the initial network settings based on your network infrastructure to enable the communication to and from iDRAC.

You must use the default iDRAC IP address 192.168.0.120 to configure the initial network settings, including setting up DHCP or a static IP for iDRAC. You can set up the IP address by using one of the following interfaces:

Interfaces	Document/Section
iDRAC Settings utility	See <i>Dell Integrated Dell Remote Access Controller User's Guide</i> at <a href="http://Dell.com/idracmanuals">Dell.com/idracmanuals</a>
Dell Deployment Toolkit	See <i>Dell Deployment Toolkit User's Guide</i> at <a href="http://Dell.com/openmanagemanuals">Dell.com/openmanagemanuals</a>
Dell Lifecycle Controller	See <i>Dell Lifecycle Controller User's Guide</i> at <a href="http://Dell.com/idracmanuals">Dell.com/idracmanuals</a>
Chassis or Server LCD panel	See the LCD panel section

## Interfaces Document/Section

iDRAC Direct and Quick Sync 2 (optional) See *Dell Integrated Dell Remote Access Controller User's Guide* at [Dell.com/idracmanuals](https://dell.com/idracmanuals)

**NOTE:** To access iDRAC, ensure that you connect the Ethernet cable to the iDRAC direct port. You can also access iDRAC through the shared LOM mode, if you have opted for a system that has the shared LOM mode enabled.

## Log in to iDRAC

You can log in to iDRAC as:

- iDRAC user
- Microsoft Active Directory user
- Lightweight Directory Access Protocol (LDAP) user

If you have opted for secure default access to iDRAC, the iDRAC secure default password is available on the back of the system Information tag. If you have not opted for secure default access to iDRAC, then the default user name and password are `root` and `calvin`. You can also log in by using Single Sign-On or Smart Card.

**NOTE:** You must have the iDRAC credentials to log in to iDRAC.

**NOTE:** Ensure that you change the default user name and password after setting up the iDRAC IP address.

For more information about logging in to the iDRAC and iDRAC licenses, see the latest *Integrated Dell Remote Access Controller User's Guide* at [Dell.com/idracmanuals](https://dell.com/idracmanuals).

You can also access iDRAC by using RACADM. For more information, see the *RACADM Command Line Interface Reference Guide* at [Dell.com/idracmanuals](https://dell.com/idracmanuals).

## Options to install the operating system

If the system is shipped without an operating system, install the supported operating system by using one of the following resources:

**Table 32. Resources to install the operating system**

Resources	Location
Systems Management Tools and Documentation media	<a href="https://dell.com/operatingsystemmanuals">Dell.com/operatingsystemmanuals</a>
Lifecycle Controller	<a href="https://dell.com/idracmanuals">Dell.com/idracmanuals</a>
OpenManage Deployment Toolkit	<a href="https://dell.com/openmanagemanuals">Dell.com/openmanagemanuals</a>
Dell certified VMware ESXi	<a href="https://dell.com/virtualizationsolutions">Dell.com/virtualizationsolutions</a>
Supported operating systems on PowerEdge systems	<a href="https://dell.com/ossupport">Dell.com/ossupport</a>
Installation and How-to videos for supported operating systems on PowerEdge systems	<a href="#">Supported Operating Systems for Dell PowerEdge Systems</a>

## Methods to download firmware and drivers

You can download the firmware and drivers by using any of the following methods:

**Table 33. Firmware and drivers**

<b>Methods</b>	<b>Location</b>
From the Dell Support site	<a href="https://dell.com/support/home">Dell.com/support/home</a>
Using Dell Remote Access Controller Lifecycle Controller (iDRAC with LC)	<a href="https://dell.com/idracmanuals">Dell.com/idracmanuals</a>
Using Dell Repository Manager (DRM)	<a href="https://dell.com/openmanagemanuals">Dell.com/openmanagemanuals</a>
Using Dell OpenManage Essentials (OME)	<a href="https://dell.com/openmanagemanuals">Dell.com/openmanagemanuals</a>
Using Dell Server Update Utility (SUU)	<a href="https://dell.com/openmanagemanuals">Dell.com/openmanagemanuals</a>
Using Dell OpenManage Deployment Toolkit (DTK)	<a href="https://dell.com/openmanagemanuals">Dell.com/openmanagemanuals</a>

## Downloading drivers and firmware

Dell recommends that you download and install the latest BIOS, drivers, and systems management firmware on your system.

### Prerequisite

Ensure that you clear the web browser cache before downloading the drivers and firmware.

### Steps

- 1 Go to [Dell.com/support/drivers](https://dell.com/support/drivers).
- 2 In the **Drivers & Downloads** section, type the Service Tag of your system in the **Enter a Service Tag or product ID** box, and then click **Submit**.

**NOTE:** If you do not have the Service Tag, select **Detect Product** to allow the system to automatically detect your Service Tag, or click **View products**, and navigate to your product.

- 3 Click **Drivers & Downloads**.  
The drivers that are applicable to your selection are displayed.
- 4 Download the drivers to a USB drive, CD, or DVD.

# Pre-operating system management applications

You can manage basic settings and features of a system without booting to the operating system by using the system firmware.

Topics:

- [Options to manage the pre-operating system applications](#)
- [System Setup](#)
- [Dell Lifecycle Controller](#)
- [Boot Manager](#)
- [PXE boot](#)

## Options to manage the pre-operating system applications

Your system has the following options to manage the pre-operating system applications:

- System Setup
- Dell Lifecycle Controller
- Boot Manager
- Preboot Execution Environment (PXE)

## System Setup

By using the **System Setup** screen, you can configure the BIOS settings, iDRAC settings, and device settings of your system.

**NOTE:** Help text for the selected field is displayed in the graphical browser by default. To view the help text in the text browser, press F1.

You can access system setup by using two methods:

- Standard graphical browser—The browser is enabled by default.
- Text browser—The browser is enabled by using Console Redirection.

## Viewing System Setup

To view the **System Setup** screen, perform the following steps:

- 1 Turn on, or restart your system.
- 2 Press F2 immediately after you see the following message:  
F2 = System Setup

**NOTE:** If your operating system begins to load before you press F2, wait for the system to finish booting, and then restart your system and try again.

# System Setup details

The **System Setup Main Menu** screen details are explained as follows:

Option	Description
<b>System BIOS</b>	Enables you to configure BIOS settings.
<b>iDRAC Settings</b>	Enables you to configure the iDRAC settings. The iDRAC settings utility is an interface to set up and configure the iDRAC parameters by using UEFI (Unified Extensible Firmware Interface). You can enable or disable various iDRAC parameters by using the iDRAC settings utility. For more information about this utility, see <i>Integrated Dell Remote Access Controller User's Guide</i> at <a href="http://Dell.com/idracmanuals">Dell.com/idracmanuals</a> .
<b>Device Settings</b>	Enables you to configure device settings.
<b>Service Tag Settings</b>	Enables you to configure service tag settings.

## System BIOS

You can use the **System BIOS** screen to edit specific functions such as boot order, system password, setup password, set the SATA and PCIe NVMe, and enable or disable USB ports.

### Viewing System BIOS

To view the **System BIOS** screen, perform the following steps:

- 1 Turn on, or restart your system.
- 2 Press F2 immediately after you see the following message:

```
F2 = System Setup
```

**NOTE:** If your operating system begins to load before you press F2, wait for the system to finish booting, and then restart your system and try again.

- 3 On the **System Setup Main Menu** screen, click **System BIOS**.

## System BIOS Settings details

The **System BIOS Settings** screen details are explained as follows:

Option	Description
<b>System Information</b>	Specifies information about the system such as the system model name, BIOS version, and Service Tag.
<b>Memory Settings</b>	Specifies information and options related to the installed memory.
<b>Processor Settings</b>	Specifies information and options related to the processor such as speed and cache size.
<b>SATA Settings</b>	Specifies options to enable or disable the integrated SATA controller and ports.
<b>NVMe Settings</b>	Specifies options to change the NVMe settings.
<b>Boot Settings</b>	Specifies options to specify the UEFI mode.

Option	Description
<b>Network Settings</b>	Specifies options to manage the UEFI network settings and boot protocols. Legacy network settings are managed from the <b>Device Settings</b> menu.
<b>Integrated Devices</b>	Specifies options to manage integrated device controllers and ports, specifies related features and options.
<b>Serial Communication</b>	Specifies options to manage the serial ports, its related features and options.
<b>System Profile Settings</b>	Specifies options to change the processor power management settings, memory frequency.
<b>System Security</b>	Specifies options to configure the system security settings, such as system password, setup password, Trusted Platform Module (TPM) security, and UEFI secure boot. It also manages the power button on the system.
<b>Redundant OS Control</b>	Sets the redundant OS info for redundant OS control.
<b>Miscellaneous Settings</b>	Specifies options to change the system date and time.

## System Information

You can use the **System Information** screen to view system properties such as Service Tag, system model name, and the BIOS version.

## Viewing System BIOS

To view the **System BIOS** screen, perform the following steps:

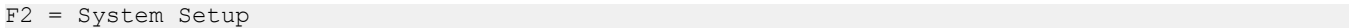
- 1 Turn on, or restart your system.
- 2 Press F2 immediately after you see the following message:  

- 3 On the **System Setup Main Menu** screen, click **System BIOS**.

**NOTE:** If your operating system begins to load before you press F2, wait for the system to finish booting, and then restart your system and try again.

## System Information details

The **System Information** screen details are explained as follows:

Option	Description
<b>System Model Name</b>	Specifies the system model name.
<b>System BIOS Version</b>	Specifies the BIOS version installed on the system.
<b>System Service Tag</b>	Specifies the system Service Tag.
<b>System Manufacturer</b>	Specifies the name of the system manufacturer.
<b>System Manufacturer</b>	Specifies the contact information of the system manufacturer.

Option	Description
<b>Contact Information</b>	
<b>System CPLD Version</b>	Specifies the current version of the system complex programmable logic device (CPLD) firmware.
<b>UEFI Compliance Version</b>	Specifies the UEFI compliance level of the system firmware.

## Memory Settings

You can use the **Memory Settings** screen to view all the memory settings and enable or disable specific memory functions, such as system memory testing and node interleaving.

### Viewing Memory Settings

To view the **Memory Settings** screen, perform the following steps:

- 1 Turn on, or restart your system.
- 2 Press F2 immediately after you see the following message:  

```
F2 = System Setup
```
- 3 On the **System Setup Main Menu** screen, click **System BIOS**.
- 4 On the **System BIOS** screen, click **Memory Settings**.

**NOTE:** If your operating system begins to load before you press F2, wait for the system to finish booting, and then restart your system and try again.

### Memory Settings details

The **Memory Settings** screen details are explained as follows:

Option	Description
<b>System Memory Size</b>	Specifies the memory size in the system.
<b>System Memory Type</b>	Specifies the type of memory installed in the system.
<b>System Memory Speed</b>	Specifies the system memory speed.
<b>System Memory Voltage</b>	Specifies the system memory voltage.
<b>Video Memory</b>	Specifies the amount of video memory.
<b>System Memory Testing</b>	Specifies whether the system memory tests are run during system boot. Options are <b>Enabled</b> and <b>Disabled</b> . This option is set to <b>Disabled</b> by default.
<b>Memory Operating Mode</b>	Specifies the memory operating mode. The option available is <b>Optimizer Mode</b> . This option is set to <b>Optimizer Mode</b> by default.
<b>Current State of Memory Operating Mode</b>	Specifies the current state of the memory operating mode.

Option	Description
<b>Memory Interleaving</b>	Specifies if Non-Uniform Memory Architecture (NUMA) is supported.

**Table 34. Memory interleaving options**

Memory	Options
Single memory module	<b>Disabled</b> by default
Two or more memory modules	<ul style="list-style-type: none"> <li>• <b>Disabled</b></li> <li>• <b>Channel Interleaving</b></li> <li>• <b>Die Interleaving</b></li> </ul>

Memory Interleaving is set to **Channel Interleaving** by default.

**NOTE:** The AMD EPYC micro architecture utilizes four NUMA per socket. An additional performance fine tuning and/or NUMA-aware software is required for best performance.

<b>Opportunistic Self-Refresh</b>	Enables or disables opportunistic self-refresh feature. This option is set to <b>Disabled</b> by default.
-----------------------------------	---

## Processor Settings

You can use the **Processor Settings** screen to view the processor settings, and perform specific functions such as enabling virtualization technology, hardware prefetcher and software prefetcher.

## Viewing Processor Settings

To view the **Processor Settings** screen, perform the following steps:

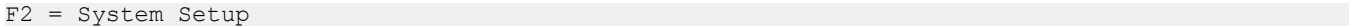
- 1 Turn on, or restart your system.
- 2 Press F2 immediately after you see the following message:  

**NOTE:** If your operating system begins to load before you press F2, wait for the system to finish booting, and then restart your system and try again.

- 3 On the **System Setup Main Menu** screen, click **System BIOS**.
- 4 On the **System BIOS** screen, click **Processor Settings**.

## Processor Settings details

The **Processor Settings** screen details are explained as follows:

Option	Description
<b>Logical Processor</b>	Each processor core supports up to two logical processors. If this option is set to <b>Enabled</b> , the BIOS displays all the logical processors. If this option is set to <b>Disabled</b> , the BIOS displays only one logical processor per core. This option is set to <b>Enabled</b> by default.
<b>Virtualization Technology</b>	Enables or disables the virtualization technology for the processor. This option is set to <b>Enabled</b> by default.
<b>Hardware Prefetcher</b>	Enables or disables the hardware prefetcher. This option is set to <b>Enabled</b> by default.

Option	Description
<b>Software Prefetcher</b>	Enables or disables the software prefetcher. This option is set to <b>Enabled</b> by default.
<b>Number of Cores per Processor</b>	Controls the number of enabled cores in each processor. This option is set to <b>All</b> by default.
<b>Processor Core Speed</b>	Specifies the maximum core frequency of the processor.

#### Processor n

 **NOTE:** Depending on the number of CPUs, there might be up to n processors listed.

The following settings are displayed for each processor installed in the system:

Option	Description
<b>Family-Model-Stepping</b>	Specifies the family, model, and stepping of the processor as defined by AMD.
<b>Brand</b>	Specifies the brand name.
<b>Level 2 Cache</b>	Specifies the total L2 cache.
<b>Level 3 Cache</b>	Specifies the total L3 cache.
<b>Number of Cores</b>	Specifies the number of cores per processor.

## SATA Settings

You can use the **SATA Settings** screen to view the SATA settings of SATA devices and enable SATA and PCIe NVMe on your system.

## Viewing SATA Settings

To view the **SATA Settings** screen, perform the following steps:

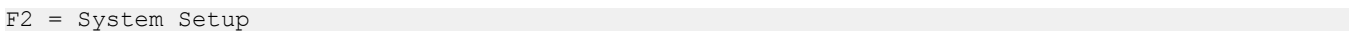
- 1 Turn on, or restart your system.
- 2 Press F2 immediately after you see the following message:  

 **NOTE:** If your operating system begins to load before you press F2, wait for the system to finish booting, and then restart your system and try again.

- 3 On the **System Setup Main Menu** screen, click **System BIOS**.
- 4 On the **System BIOS** screen, click **SATA Settings**.

## SATA Settings details

The **SATA Settings** screen details are explained as follows:

Option	Description
<b>Embedded SATA</b>	Enables the embedded SATA option to be set to <b>Off</b> or <b>AHCI</b> modes. This option is set to <b>AHCI Mode</b> by default.
<b>Security Freeze Lock</b>	Sends <b>Security Freeze Lock</b> command to the embedded SATA drives during POST. This option is applicable only for AHCI Mode. This option is set to <b>Enabled</b> by default.
<b>Write Cache</b>	Enables or disables the command for the embedded SATA drives during POST. This option is set to <b>Disabled</b> by default.

Option	Description
<b>Port n</b>	Sets the drive type of the selected device. For <b>AHCI Mode</b> , BIOS support is always enabled.

Option	Description
<b>Model</b>	Specifies the drive model of the selected device.
<b>Drive Type</b>	Specifies the type of drive attached to the SATA port.
<b>Capacity</b>	Specifies the total capacity of the drive. This field is undefined for removable media devices such as optical drives.

## NVMe Settings

The NVMe settings is set to **Non-RAID** mode.

## Viewing NVMe Settings

To view the **NVMe Settings** screen, perform the following steps:

- 1 Turn on, or restart your system.
- 2 Press F2 immediately after you see the following message:

F2 = System Setup

**NOTE:** If your operating system begins to load before you press F2, wait for the system to finish booting, and then restart your system and try again.

- 3 On the **System Setup Main Menu** screen, click **System BIOS**.
- 4 On the **System BIOS** screen, click **NVMe Settings**.

## NVMe Settings details

**NOTE:** This setting is disabled by default.

The NVMe Settings screen details are explained as follows:

Option	Description
<b>NVMe Mode</b>	Enables you to set the NVMe mode. This option is set to <b>Non RAID</b> by default.

## Boot Settings

- **UEFI:** The Unified Extensible Firmware Interface (UEFI) is a new interface between operating systems and platform firmware. The interface consists of data tables with platform related information, also boot and runtime service calls that are available to the operating system and its loader. The following benefits are available when the booting to the **UEFI**:
  - Support for drive partitions larger than 2 TB.
  - Enhanced security (e.g., UEFI Secure Boot).
  - Faster boot time.

## Viewing Boot Settings

To view the **Boot Settings** screen, perform the following steps:

- 1 Turn on, or restart your system.
- 2 Press F2 immediately after you see the following message:

F2 = System Setup

**NOTE:** If your operating system begins to load before you press F2, wait for the system to finish booting, and then restart your system and try again.

- 3 On the **System Setup Main Menu** screen, click **System BIOS**.
- 4 On the **System BIOS** screen, click **Boot Settings**.

## Boot Settings details

The **Boot Settings** screen details are explained as follows:

Option	Description
<b>Boot Mode</b>	Specifies the Boot Mode of the system. This option is set to <b>UEFI</b> by default.
<b>Boot Sequence Retry</b>	Enables or disables the <b>Boot Sequence Retry</b> feature. If this option is set to <b>Enabled</b> and the system fails to boot, the system re-attempts the boot sequence after 30 seconds. This option is set to <b>Enabled</b> by default.
<b>UEFI Boot Settings</b>	Enables or disables UEFI Boot options. <b>NOTE:</b> This option is enabled only if the boot mode is UEFI.

## Network Settings

You can use the **Network Settings** screen to modify UEFI PXE, iSCSI, and HTTP boot settings. The network settings option is available only in the UEFI mode.

**NOTE:** For information about Linux network settings, see the *Linux® Network Tuning Guide for AMD EPYC™ Processor Based Servers* AMD tuning guide.

## Viewing Network Settings

To view the **Network Settings** screen, perform the following steps:

- 1 Turn on, or restart your system.
- 2 Press F2 immediately after you see the following message:

F2 = System Setup

**NOTE:** If your operating system begins to load before you press F2, wait for the system to finish booting, and then restart your system and try again.

- 3 On the **System Setup Main Menu** screen, click **System BIOS**.
- 4 On the **System BIOS** screen, click **Network Settings**.

## Network Settings screen details

The **Network Settings** screen details are explained as follows:

Option	Description
<b>PXE Device n</b> (n = 1 to 4)	Enables or disables the device. When enabled, a UEFI PXE boot option is created for the device.
<b>PXE Device n Settings</b> (n = 1 to 4)	Enables you to control the configuration of the PXE device.
<b>HTTP Device n</b> (n = 1 to 4)	Enables or disables the device. When enabled, a UEFI HTTP boot option is created for the device.
<b>HTTP Device n Settings</b> (n = 1 to 4)	Enables you to control the configuration of the HTTP device.

**NOTE:** Ensure that you configure the PXE boot environment to be UEFI compatible.

## UEFI iSCSI Settings

You can use the iSCSI Settings screen to modify iSCSI device settings. The iSCSI Settings option is available only in the UEFI boot mode.

### Viewing UEFI iSCSI Settings

To view the **UEFI iSCSI Settings** screen, perform the following steps:

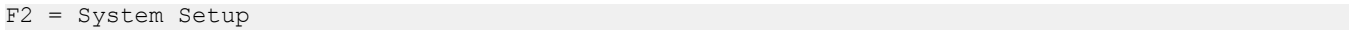
- 1 Turn on, or restart your system.
- 2 Press F2 immediately after you see the following message:  

- 3 On the **System Setup Main Menu** screen, click **System BIOS**.
- 4 On the **System BIOS** screen, click **Network Settings**.
- 5 On the **Network Settings** screen, click **UEFI iSCSI Settings**.

**NOTE:** If your operating system begins to load before you press F2, wait for the system to finish booting, and then restart your system and try again.

### UEFI iSCSI Settings details

The **UEFI iSCSI Settings** screen details are explained as follows:

Option	Description
<b>iSCSI Initiator Name</b>	Specifies the name of the iSCSI initiator (iqn format).
<b>iSCSI Device1</b>	Enables or disables the iSCSI device. When disabled, a UEFI boot option is created for the iSCSI device automatically.
<b>iSCSI Device1 Settings</b>	Enables you to control the configuration of the iSCSI device.

# Integrated Devices

You can use the **Integrated Devices** screen to view and configure the settings of all integrated devices including the video controller, integrated RAID controller, and the USB ports.

## Viewing Integrated Devices

To view the **Integrated Devices** screen, perform the following steps:

- 1 Turn on, or restart your system.
- 2 Press F2 immediately after you see the following message:

F2 = System Setup

**NOTE:** If your operating system begins to load before you press F2, wait for the system to finish booting, and then restart your system and try again.

- 3 On the **System Setup Main Menu** screen, click **System BIOS**.
- 4 On the **System BIOS** screen, click **Integrated Devices**.

## Integrated Devices details

The **Integrated Devices** screen details are explained as follows:

Option	Description
<b>User Accessible USB Ports</b>	<p>Configures the user accessible USB ports. Selecting <b>Only Back Ports On</b> disables the front USB ports; selecting <b>All Ports Off</b> disables all front and back USB ports.</p> <p>The USB keyboard and mouse still function in certain USB ports during the boot process, depending on the selection. After the boot process is complete, the USB ports will be enabled or disabled as per the setting.</p>
<b>Internal USB Port</b>	<p>Enables or disables the internal USB port. This option is set to <b>On</b> or <b>Off</b>. This option is set to <b>On</b> by default.</p>
<b>Integrated RAID Controller</b>	<p>Enables or disables the integrated RAID controller. This option is set to <b>Enabled</b> by default.</p>
<b>Embedded NIC1 and NIC2</b>	<p><b>NOTE:</b> The Embedded NIC1 and NIC2 options are only available on systems that do not have Integrated Network Card 1.</p> <p>Enables or disables the Embedded NIC1 and NIC2 options. If set to <b>Disabled</b>, the NIC may still be available for shared network access by the embedded management controller. The embedded NIC1 and NIC2 options are only available on systems that do not have Network Daughter Cards (NDCs). The Embedded NIC1 and NIC2 option is mutually exclusive with the Integrated Network Card 1 option. Configure the Embedded NIC1 and NIC2 option by using the NIC management utilities of the system.</p>
<b>Embedded Video Controller</b>	<p>Enables or disables the use of Embedded Video Controller as the primary display. When set to <b>Enabled</b>, the Embedded Video Controller will be the primary display even if add-in graphic cards are installed. When set to <b>Disabled</b>, an add-in graphics card will be used as the primary display. BIOS will output displays to both the primary add-in video and the embedded video during POST and pre-boot environment. The embedded video will then be disabled right before the operating system boots. This option is set to <b>Enabled</b> by default.</p> <p><b>NOTE:</b> When there are multiple add-in graphic cards installed in the system, the first card discovered during PCI enumeration is selected as the primary video. You might have to re-arrange the cards in the slots in order to control which card is the primary video.</p>

Option	Description
<b>Current State of Embedded Video Controller</b>	Displays the current state of the embedded video controller. The <b>Current State of Embedded Video Controller</b> option is a read-only field. If the Embedded Video Controller is the only display capability in the system (that is, no add-in graphics card is installed), then the Embedded Video Controller is automatically used as the primary display even if the <b>Embedded Video Controller</b> setting is set to <b>Disabled</b> .
<b>SR-IOV Global Enable</b>	Enables or disables the BIOS configuration of Single Root I/O Virtualization (SR-IOV) devices. This option is set to <b>Disabled</b> by default.
<b>Internal MicroSD Card Port</b>	Enables or disables the internal MicroSD card port of the Internal Dual SD Module (IDSDM). This option is set to <b>On</b> by default.
<b>Internal MicroSD Card Redundancy</b>	Configures the redundancy mode of the Internal Dual SD Module (IDSDM). When set to <b>Mirror</b> Mode, data is written on both MicroSD cards. After failure of either card and replacement of the failed card, the data of the active card is copied to the offline card during the system boot.  When Internal SD Card Redundancy is set to <b>Disabled</b> , only the primary MicroSD card is visible to the OS. This option is set to <b>Disabled</b> by default.
<b>Internal microSD Primary Card</b>	When <b>Redundancy</b> is set to <b>Disabled</b> , either one of the MicroSD card can be selected to present itself as mass storage device by setting it to be primary card. By default primary MicroSD card is selected to be SD Card 1. If MicroSD Card 1 is not present, then the controller will select MicroSD Card 2 to be the primary MicroSD card.
<b>OS Watchdog Timer</b>	If your system stops responding, this watchdog timer aids in the recovery of your operating system. When this option is set to <b>Enabled</b> , the operating system initializes the timer. When this option is set to <b>Disabled</b> (the default), the timer does not have any effect on the system.
<b>Memory Mapped I/O Limit</b>	Controls where MMIO is mapped. The <b>1 TB</b> option is designed for specific OS which cannot support MMIO over 1 TB. This option is set to <b>8 TB</b> by default. The default option is the maximum address that the system supports and recommended in most cases.
<b>Slot Disablement</b>	Enables or disables the available PCIe slots on your system. The slot disablement feature controls the configuration of the PCIe cards installed in the specified slot. Slots must be disabled only when the installed peripheral card prevents booting into the operating system or causes delays in system startup. If the slot is disabled, both the Option ROM and UEFI drivers are disabled. Only slots that are present on the system will be available for control.

**Table 35. Slot Disablement**

Option	Description
<b>Slot 1</b>	Enables or disables or only the boot driver is disabled for the PCIe slot 1. This option is set to <b>Enabled</b> by default.
<b>Slot 2</b>	Enables or disables or only the boot driver is disabled for the PCIe slot 2. This option is set to <b>Enabled</b> by default.
<b>Slot 3</b>	Enables or disables or only the boot driver is disabled for the PCIe slot 3. This option is set to <b>Enabled</b> by default.

<b>Slot Bifurcation</b>	Allows <b>Platform Default Bifurcation</b> and <b>Manual bifurcation Control</b> . The default is set to <b>Platform Default Bifurcation</b> . The slot bifurcation field is accessible when set to <b>Manual bifurcation Control</b> and is grayed out when set to <b>Platform Default Bifurcation</b> .
-------------------------	---

**Table 36. Slot Bifurcation**

Option	Description
<b>Slot 1 Bifurcation</b>	x8 Bifurcation
<b>Slot 2 Bifurcation</b>	x16 or x8 or x4 or x2 Bifurcation

Option	Description
<b>Slot 3 Bifurcation</b>	x16 or x8 or x4 or x2 Bifurcation

## Serial Communication

You can use the **Serial Communication** screen to view the properties of the serial communication port.

### Viewing Serial Communication

To view the **Serial Communication** screen, perform the following steps:

- 1 Turn on, or restart your system.
- 2 Press F2 immediately after you see the following message:  

```
F2 = System Setup
```

**NOTE:** If your operating system begins to load before you press F2, wait for the system to finish booting, and then restart your system and try again.

- 3 On the **System Setup Main Menu** screen, click **System BIOS**.
- 4 On the **System BIOS** screen, click **Serial Communication**.

### Serial Communication details

The **Serial Communication** screen details are explained as follows:

Option	Description
<b>Serial Communication</b>	Selects serial communication devices (Serial Device 1 and Serial Device 2) in BIOS. BIOS console redirection can also be enabled, and the port address can be specified. This option is set to <b>Auto</b> by default.
<b>Serial Port Address</b>	Enables you to set the port address for serial devices. This option is set to <b>Serial Device1=COM2, Serial Device 2=COM1</b> by default. <ul style="list-style-type: none"> <li><b>NOTE:</b> You can use only Serial Device 2 for the Serial Over LAN (SOL) feature. To use console redirection by SOL, configure the same port address for console redirection and the serial device.</li> <li><b>NOTE:</b> Every time the system boots, the BIOS syncs the serial MUX setting saved in iDRAC. The serial MUX setting can independently be changed in iDRAC. Loading the BIOS default settings from within the BIOS setup utility may not always revert the serial MUX setting to the default setting of Serial Device 1.</li> </ul>
<b>External Serial Connector</b>	Enables you to associate the External Serial Connector to <b>Serial Device 1, Serial Device 2,</b> or the <b>Remote Access Device</b> by using this option. This option is set to <b>Serial Device 1</b> by default. <ul style="list-style-type: none"> <li><b>NOTE:</b> Only Serial Device 2 can be used for Serial Over LAN (SOL). To use console redirection by SOL, configure the same port address for console redirection and the serial device.</li> <li><b>NOTE:</b> Every time the system boots, the BIOS syncs the serial MUX setting saved in iDRAC. The serial MUX setting can independently be changed in iDRAC. Loading the BIOS default settings from within the BIOS setup utility may not always revert this setting to the default setting of Serial Device 1.</li> </ul>

Option	Description
<b>Failsafe Baud Rate</b>	Specifies the failsafe baud rate for console redirection. The BIOS attempts to determine the baud rate automatically. This failsafe baud rate is used only if the attempt fails, and the value must not be changed. This option is set to <b>115200</b> by default.
<b>Remote Terminal Type</b>	Sets the remote console terminal type. This option is set to <b>VT100/VT220</b> by default.
<b>Redirection After Boot</b>	Enables or disables the BIOS console redirection when the operating system is loaded. This option is set to <b>Enabled</b> by default.

## System Profile Settings

You can use the **System Profile Settings** screen to enable specific system performance settings such as power management.

### Viewing System Profile Settings

To view the **System Profile Settings** screen, perform the following steps:

- 1 Turn on, or restart your system.
- 2 Press F2 immediately after you see the following message:

F2 = System Setup

**NOTE:** If your operating system begins to load before you press F2, wait for the system to finish booting, and then restart your system and try again.

- 3 On the **System Setup Main Menu** screen, click **System BIOS**.
- 4 On the **System BIOS** screen, click **System Profile Settings**.

### System Profile Settings details

The **System Profile Settings** screen details are explained as follows:

Option	Description
<b>System Profile</b>	Sets the system profile. If you set the System Profile option to a mode other than <b>Custom</b> , the BIOS automatically sets the rest of the options. You can only change the rest of the options if the mode is set to <b>Custom</b> . This option is set to <b>Performance Per Watt (OS)</b> by default. Other options include <b>Performance</b> and <b>Custom</b> .  <b>NOTE:</b> All the parameters on the system profile setting screen are available only when the <b>System Profile</b> option is set to <b>Custom</b> .
<b>CPU Power Management</b>	Sets the CPU power management. This option is set to <b>OS DBPM</b> by default. Other option includes <b>Maximum Performance</b> .
<b>Memory Frequency</b>	Sets the speed of the system memory. You can select <b>Maximum Performance</b> or a specific speed. This option is set to <b>Maximum Performance</b> by default.
<b>Turbo Boost</b>	Enables or disables the processor to operate in the turbo boost mode. This option is set to <b>Enabled</b> by default.
<b>C States</b>	Enables or disables the processor to operate in all available power states. This option is set to <b>Enabled</b> by default.
<b>Memory Patrol Scrub</b>	Sets the memory patrol scrub frequency. This option is set to <b>Standard</b> by default.
<b>Memory Refresh Rate</b>	Sets the memory refresh rate to either 1x or 2x. This option is set to <b>1x</b> by default.

Option	Description
<b>PCI ASPM L1 Link Power Management</b>	Enables or disables the PCI ASPM L1 Link Power Management. This option is set to <b>Enabled</b> by default.

## System Security

You can use the **System Security** screen to perform specific functions such as setting the system password, setup password and disabling the power button.

### Viewing System Security

To view the **System Security** screen, perform the following steps:

- 1 Turn on, or restart your system.
- 2 Press F2 immediately after you see the following message:  
F2 = System Setup

**NOTE:** If your operating system begins to load before you press F2, wait for the system to finish booting, and then restart your system and try again.

- 3 On the **System Setup Main Menu** screen, click **System BIOS**.
- 4 On the **System BIOS** screen, click **System Security**.

### System Security Settings details

The **System Security Settings** screen details are explained as follows:

Option	Description
<b>CPU AES-NI</b>	Improves the speed of applications by performing encryption and decryption by using the Advanced Encryption Standard Instruction Set (AES-NI). This option is set to <b>Enabled</b> by default.
<b>System Password</b>	Sets the system password. This option is set to <b>Enabled</b> by default and is read-only if the password jumper is not installed in the system.
<b>Setup Password</b>	Sets the setup password. This option is read-only if the password jumper is not installed in the system.
<b>Password Status</b>	Locks the system password. This option is set to <b>Unlocked</b> by default.
<b>TPM Security</b>	<p><b>NOTE:</b> The TPM menu is available only when the TPM module is installed.</p> <p>Enables you to control the reporting mode of the TPM. The <b>TPM Security</b> option is set to <b>Off</b> by default. You can only modify the TPM Status, and TPM Activation if the <b>TPM Status</b> field is set to either <b>On with Pre-boot Measurements</b> or <b>On without Pre-boot Measurements</b>.</p> <p>When TPM 1.2 is installed, the <b>TPM Security</b> option is set to <b>Off</b>, <b>On with Pre-boot Measurements</b>, or <b>On without Pre-boot Measurements</b>.</p>

**Table 37. TPM 1.2 security information**

<b>TPM Information</b>	Changes the operational state of the TPM. This option is set to <b>No Change</b> by default.
<b>TPM Firmware</b>	Indicates the firmware version of the TPM.
<b>TPM Status</b>	Specifies the TPM status.

Option	Description
<b>TPM Command</b>	Controls the Trusted Platform Module (TPM). When set to <b>None</b> , no command is sent to the TPM. When set to <b>Activate</b> , the TPM is enabled and activated. When set to <b>Deactivate</b> , the TPM is disabled and deactivated. When set to <b>Clear</b> , all the contents of the TPM are cleared. This option is set to <b>None</b> by default.

When TPM 2.0 is installed, the **TPM Security** option is set to **On** or **Off**. This option is set to **Off** by default.

**Table 38. TPM 2.0 security information**

<b>TPM Information</b>	Changes the operational state of the TPM. This option is set to <b>No Change</b> by default.
<b>TPM Firmware</b>	Indicates the firmware version of the TPM.
<b>TPM Hierarchy</b>	<p>Enable, disable, or clear the storage and endorsement hierarchies. When set to <b>Enabled</b>, the storage and endorsement hierarchies can be used.</p> <p>When set to <b>Disabled</b>, the storage and endorsement hierarchies cannot be used.</p> <p>When set to <b>Clear</b>, the storage and endorsement hierarchies are cleared of any values, and then reset to <b>Enabled</b>.</p>

<b>Power Button</b>	Enables or disables the power button on the front of the system. This option is set to <b>Enabled</b> by default.
<b>AC Power Recovery</b>	Sets how the system behaves after AC power is restored to the system. This option is set to <b>Last</b> by default.
<b>AC Power Recovery Delay</b>	Sets the time delay for the system to power up after AC power is restored to the system. This option is set to <b>Immediate</b> by default.
<b>User Defined Delay (60 s to 240 s)</b>	Sets the <b>User Defined Delay</b> option when the <b>User Defined</b> option for <b>AC Power Recovery Delay</b> is selected.
<b>UEFI Variable Access</b>	Provides varying degrees of securing UEFI variables. When set to <b>Standard</b> (the default), UEFI variables are accessible in the operating system per the UEFI specification. When set to <b>Controlled</b> , selected UEFI variables are protected in the environment and new UEFI boot entries are forced to be at the end of the current boot order.
<b>Secure Boot</b>	Enables Secure Boot, where the BIOS authenticates each pre-boot image by using the certificates in the Secure Boot Policy. Secure Boot is set to <b>Disabled</b> by default.
<b>Secure Boot Policy</b>	When Secure Boot policy is set to <b>Standard</b> , the BIOS uses the system manufacturer's key and certificates to authenticate pre-boot images. When Secure Boot policy is set to <b>Custom</b> , the BIOS uses the user-defined key and certificates. Secure Boot policy is set to <b>Standard</b> by default.
<b>Secure Boot Mode</b>	Configures how the BIOS uses the Secure Boot Policy Objects (PK, KEK, db, dbx). If the current mode is set to <b>Deployed Mode</b> , the available options are <b>User Mode</b> and <b>Deployed Mode</b> . If the current mode is set to <b>User Mode</b> , the available options are <b>User Mode</b> , <b>Audit Mode</b> , and <b>Deployed Mode</b> .

Options	Description
<b>User Mode</b>	<p>In <b>User Mode</b>, PK must be installed, and BIOS performs signature verification on programmatic attempts to update policy objects.</p> <p>The BIOS allows unauthenticated programmatic transitions between modes.</p>

Option	Description						
	<table border="1"> <thead> <tr> <th>Options</th> <th>Description</th> </tr> </thead> <tbody> <tr> <td><b>Deployed Mode</b></td> <td> <p><b>Deployed Mode</b> is the most secure mode. In <b>Deployed Mode</b>, PK must be installed and the BIOS performs signature verification on programmatic attempts to update policy objects.</p> <p><b>Deployed Mode</b> restricts the programmatic mode transitions.</p> </td> </tr> <tr> <td><b>Audit Mode</b></td> <td> <p>In <b>Audit mode</b>, PK is not present. The BIOS does not authenticate programmatic updates to the policy objects, and transitions between modes. The BIOS performs a signature verification on pre-boot images and logs the results in the image Execution Information Table, but executes the images whether they pass or fail verification.</p> <p><b>Audit Mode</b> is useful for programmatic determination of a working set of policy objects.</p> </td> </tr> </tbody> </table>	Options	Description	<b>Deployed Mode</b>	<p><b>Deployed Mode</b> is the most secure mode. In <b>Deployed Mode</b>, PK must be installed and the BIOS performs signature verification on programmatic attempts to update policy objects.</p> <p><b>Deployed Mode</b> restricts the programmatic mode transitions.</p>	<b>Audit Mode</b>	<p>In <b>Audit mode</b>, PK is not present. The BIOS does not authenticate programmatic updates to the policy objects, and transitions between modes. The BIOS performs a signature verification on pre-boot images and logs the results in the image Execution Information Table, but executes the images whether they pass or fail verification.</p> <p><b>Audit Mode</b> is useful for programmatic determination of a working set of policy objects.</p>
Options	Description						
<b>Deployed Mode</b>	<p><b>Deployed Mode</b> is the most secure mode. In <b>Deployed Mode</b>, PK must be installed and the BIOS performs signature verification on programmatic attempts to update policy objects.</p> <p><b>Deployed Mode</b> restricts the programmatic mode transitions.</p>						
<b>Audit Mode</b>	<p>In <b>Audit mode</b>, PK is not present. The BIOS does not authenticate programmatic updates to the policy objects, and transitions between modes. The BIOS performs a signature verification on pre-boot images and logs the results in the image Execution Information Table, but executes the images whether they pass or fail verification.</p> <p><b>Audit Mode</b> is useful for programmatic determination of a working set of policy objects.</p>						

**Secure Boot Policy Summary** Specifies the list of certificates and hashes that secure boot uses to authenticate images.

**Secure Boot Custom Policy Settings** Configures the Secure Boot Custom Policy. To enable this option, set the Secure Boot Policy to **Custom** option.

## Creating a system and setup password

### Prerequisite

Ensure that the password jumper is enabled. The password jumper enables or disables the system password and setup password features. For more information, see the System board jumper settings section.

**NOTE:** If the password jumper setting is disabled, the existing system password and setup password are deleted and you need not provide the system password to boot the system.

### Steps

- 1 To enter System Setup, press F2 immediately after turning on or rebooting your system.
- 2 On the **System Setup Main Menu** screen, click **System BIOS > System Security**.
- 3 On the **System Security** screen, verify that **Password Status** is set to **Unlocked**.
- 4 In the **System Password** field, type your system password, and press Enter or Tab.

Use the following guidelines to assign the system password:

- A password can have up to 32 characters.
- The password can contain the numbers 0 through 9.
- Only the following special characters are allowed: space, ("), (+), (.), (-), (.), (/), (:), ([), (\), (]), (`).

A message prompts you to reenter the system password.

- 5 Reenter the system password, and click **OK**.
  - 6 In the **Setup Password** field, type your setup password and press Enter or Tab.
- A message prompts you to reenter the setup password.
- 7 Reenter the setup password, and click **OK**.
  - 8 Press Esc to return to the System BIOS screen. Press Esc again.

A message prompts you to save the changes.

**NOTE:** Password protection does not take effect until the system reboots.

## Using your system password to secure your system

### About this task

If you have assigned a setup password, the system accepts your setup password as an alternate system password.

### Steps

- 1 Turn on or reboot your system.
- 2 Type the system password and press Enter.

### Next step

When **Password Status** is set to **Locked**, type the system password and press Enter when prompted at reboot.

**NOTE:** If an incorrect system password is typed, the system displays a message and prompts you to reenter your password. You have three attempts to type the correct password. After the third unsuccessful attempt, the system displays an error message that the system has stopped functioning and must be turned off. Even after you turn off and restart the system, the error message is displayed until the correct password is entered.

## Deleting or changing system and setup password

### Prerequisite

**NOTE:** You cannot delete or change an existing system or setup password if the **Password Status** is set to **Locked**.

### Steps

- 1 To enter System Setup, press F2 immediately after turning on or restarting your system.
- 2 On the **System Setup Main Menu** screen, click **System BIOS > System Security**.
- 3 On the **System Security** screen, ensure that **Password Status** is set to **Unlocked**.
- 4 In the **System Password** field, alter or delete the existing system password, and then press Enter or Tab.
- 5 In the **Setup Password** field, alter or delete the existing setup password, and then press Enter or Tab.  
If you change the system and setup password, a message prompts you to reenter the new password. If you delete the system and setup password, a message prompts you to confirm the deletion.
- 6 Press Esc to return to the **System BIOS** screen. Press Esc again, and a message prompts you to save the changes.
- 7 Select **Setup Password**, change, or delete the existing setup password and press Enter or Tab.

**NOTE:** If you change the system password or setup password, a message prompts you to reenter the new password. If you delete the system password or setup password, a message prompts you to confirm the deletion.

## Operating with setup password enabled

If **Setup Password** is set to **Enabled**, type the correct setup password before modifying the system setup options.

If you do not type the correct password in three attempts, the system displays the following message:

```
Invalid Password! Number of unsuccessful password attempts: <x> System Halted! Must power down.
```

```
Password Invalid. Number of unsuccessful password attempts: <x> Maximum number of password attempts exceeded.System halted.
```

Even after you turn off and restart the system, the error message is displayed until the correct password is typed. The following options are exceptions:

- If **System Password** is not set to **Enabled** and is not locked through the **Password Status** option, you can assign a system password. For more information, see the System Security Settings screen section.

- You cannot disable or change an existing system password.

**NOTE:** You can use the password status option with the setup password option to protect the system password from unauthorized changes.

## Redundant OS Control

You can use the **Redundant OS Control** screen to set the redundant OS info for redundant OS control. It enables you to set up a physical recovery disk on your system.

## Viewing Redundant OS Control

To view the **Redundant OS Control** screen, perform the following steps:

- 1 Turn on, or restart your system.
- 2 Press F2 immediately after you see the following message:  
F2 = System Setup

**NOTE:** If your operating system begins to load before you press F2, wait for the system to finish booting, and then restart your system and try again.

- 3 On the **System Setup Main Menu** screen, click **System BIOS**.
- 4 On the **System BIOS** screen, click **Redundant OS Control**.

## Redundant OS Control screen details

The **Redundant OS Control** screen details are explained as follows:

Option	Description
<b>Redundant OS Location</b>	<p>Enables you to select a backup disk from the following devices:</p> <ul style="list-style-type: none"> <li>· <b>None</b></li> <li>· <b>IDSDM</b></li> <li>· <b>SATA Ports in AHCI mode</b></li> <li>· <b>BOSS PCIe Cards (Internal M.2 Drives)</b></li> <li>· <b>Internal USB</b></li> </ul> <p><b>NOTE:</b> RAID configurations and NVMe cards not are included as BIOS does not have the ability to distinguish between individual drives in those configurations.</p>
<b>Redundant OS State</b>	<p><b>NOTE:</b> This option is disabled if <b>Redundant OS Location</b> is set to <b>None</b>.</p> <p>When set to <b>Visible</b>, the backup disk is visible to the boot list and OS. When set to <b>Hidden</b>, the backup disk is disabled and is not visible to the boot list and OS. This option is set to <b>Visible</b> by default.</p> <p><b>NOTE:</b> BIOS will disable the device in hardware, so it cannot be accessed by the OS.</p>
<b>Redundant OS Boot</b>	<p><b>NOTE:</b> This option is disabled if <b>Redundant OS Location</b> is set to <b>None</b> or if <b>Redundant OS State</b> is set to <b>Hidden</b>.</p> <p>When set to <b>Enabled</b>, BIOS boots to the device specified in <b>Redundant OS Location</b>. When set to <b>Disabled</b>, BIOS preserves the current boot list settings. This option is set to <b>Enabled</b> by default.</p>

## Miscellaneous Settings

You can use the **Miscellaneous Settings** screen to perform specific functions such as updating the asset tag and changing the system date and time.

## Viewing Miscellaneous Settings

To view the **Miscellaneous Settings** screen, perform the following steps:

- 1 Turn on, or restart your system.
- 2 Press F2 immediately after you see the following message:

F2 = System Setup

**NOTE:** If your operating system begins to load before you press F2, wait for the system to finish booting, and then restart your system and try again.

- 3 On the **System Setup Main Menu** screen, click **System BIOS**.
- 4 On the **System BIOS** screen, click **Miscellaneous Settings**.

## Miscellaneous Settings details

The **Miscellaneous Settings** screen details are explained as follows:

Option	Description
<b>System Time</b>	Enables you to set the time on the system.
<b>System Date</b>	Enables you to set the date on the system.
<b>Asset Tag</b>	Specifies the asset tag and enables you to modify it for security and tracking purposes.
<b>Keyboard NumLock</b>	Enables you to set whether the system boots with the NumLock enabled or disabled. This option is set to <b>On</b> by default. <b>NOTE:</b> This option does not apply to 84-key keyboards.
<b>F1/F2 Prompt on Error</b>	Enables or disables the F1/F2 prompt on error. This option is set to <b>Enabled</b> by default. The F1/F2 prompt also includes keyboard errors.
<b>Dell Wyse P25/P45 BIOS Access</b>	Enables or disables the Dell Wyse P25/P45 BIOS Access. This option is set to <b>Enabled</b> by default.
<b>Power Cycle Request</b>	Enables or disables the Power Cycle Request. This option is set to <b>None</b> by default.

## iDRAC Settings utility

The iDRAC settings utility is an interface to set up and configure the iDRAC parameters by using UEFI. You can enable or disable various iDRAC parameters by using the iDRAC settings utility.

**NOTE:** Accessing some of the features on the iDRAC settings utility needs the iDRAC Enterprise License upgrade.

For more information about using iDRAC, see *Dell Integrated Dell Remote Access Controller User's Guide* at [Dell.com/idracmanuals](https://www.dell.com/support/manuals/iDRAC).

# Device Settings

**Device Settings** enables you to configure device parameters.

# Dell Lifecycle Controller

Dell Lifecycle Controller (LC) provides advanced embedded systems management capabilities including system deployment, configuration, update, maintenance, and diagnosis. LC is delivered as part of the iDRAC out-of-band solution and Dell system embedded Unified Extensible Firmware Interface (UEFI) applications.

## Embedded system management

The Dell Lifecycle Controller provides advanced embedded system management throughout the system's lifecycle. The Dell Lifecycle Controller can be started during the boot sequence and can function independently of the operating system.

**NOTE:** Certain platform configurations may not support the full set of features provided by the Dell Lifecycle Controller.

For more information about setting up the Dell Lifecycle Controller, configuring hardware and firmware, and deploying the operating system, see the Dell Lifecycle Controller documentation at [Dell.com/idracmanuals](http://Dell.com/idracmanuals).

# Boot Manager

The **Boot Manager** screen enables you to select boot options and diagnostic utilities.

## Viewing Boot Manager

### About this task

To enter Boot Manager:

### Steps

- 1 Turn on, or restart your system.  
Enter the result of your step here (optional).
- 2 Press F11 when you see the following message:  
F11 = Boot Manager

If your operating system begins to load before you press F11, allow the system to complete the booting, and then restart your system and try again.

## Boot Manager main menu

Menu item	Description
<b>Continue Normal Boot</b>	The system attempts to boot to devices starting with the first item in the boot order. If the boot attempt fails, the system continues with the next item in the boot order until the boot is successful or no more boot options are found.
<b>One-shot Boot Menu</b>	Enables you to access boot menu, where you can select a one-time boot device to boot from.

Menu item	Description
<b>Launch System Setup</b>	Enables you to access System Setup.
<b>Launch Lifecycle Controller</b>	Exits the Boot Manager and invokes the Dell Lifecycle Controller program.
<b>System Utilities</b>	Enables you to launch System Utilities menu such as System Diagnostics.

## One-shot BIOS boot menu

**One-shot BIOS boot menu** enables you to select a boot device to boot from.

## System Utilities

**System Utilities** contains the following utilities that can be launched:

- Launch Diagnostics
- BIOS Update File Explorer
- Reboot System

## PXE boot

You can use the Preboot Execution Environment (PXE) option to boot and configure the networked systems remotely.

To access the **PXE boot** option, boot the system and then press F12 during POST instead of using standard Boot Sequence from BIOS Setup. It does not pull any menu or allows managing of network devices.

**NOTE:** Ensure that you configure the PXE boot environment to be UEFI compatible.

# Installing and removing system components

## Safety instructions

- ⚠ WARNING:** Whenever you need to lift the system, get others to assist you. To avoid injury, do not attempt to lift the system by yourself.
- ⚠ WARNING:** Opening or removing the system cover while the system is powered on may expose you to a risk of electric shock.
- ⚠ CAUTION:** Do not operate the system without the cover for a duration exceeding five minutes. Operating the system without the system cover can result in component damage.
- ⚠ CAUTION:** Many repairs may only be done by a certified service technician. You should only perform troubleshooting and simple repairs as authorized in your product documentation, or as directed by the online or telephone service and support team. Damage due to servicing that is not authorized by Dell is not covered by your warranty. Read and follow the safety instructions that are shipped with your product.
- 📌 NOTE:** It is recommended that you always use an antistatic mat and antistatic strap while working on components inside the system.
- ⚠ CAUTION:** To ensure proper operation and cooling, all bays in the system and system fans must be always populated with a component or a blank.

## Before working inside your system

### Prerequisite

Follow the safety guidelines listed in [Safety instructions](#).

### Steps

- 1 Turn off the system, including all attached peripherals.
- 2 Disconnect the system from the electrical outlet and disconnect the peripherals.
- 3 If applicable, remove the system from the rack.  
For more information, see the *Rack Installation Guide* at [Dell.com/poweredge manuals](https://Dell.com/poweredge manuals).
- 4 Remove the system cover.

## After working inside your system

### Prerequisite

Follow the safety guidelines listed in [Safety instructions](#).

### Steps

- 1 Install the system cover.
- 2 If applicable, install the system into the rack.  
For more information, see the *Rack Installation Guide* at [Dell.com/poweredge manuals](https://Dell.com/poweredge manuals).
- 3 Reconnect the peripherals and connect the system to the electrical outlet.
- 4 Turn on the attached peripherals and then turn on the system.

# Recommended tools

You need the following tools to perform the removal and installation procedures:

- Key to the bezel lock  
The key is required only if your system includes a bezel.
- Phillips #1 screwdriver
- Phillips #2 screwdriver
- Torx #T20 screwdriver
- 1/4 inch flat head screwdriver
- Wrist grounding strap

## Optional front bezel

An optional metal bezel is mounted on the front of the system. The front bezel displays the system branding. A lock on the bezel is used to protect unauthorized access to the drives. There are two versions of bezel available:

- With LCD panel
- Without LCD panel

For bezels with LCD panel, the system status can be viewed on the LCD panel. For more information, see the [LCD panel](#) section.

## Removing the front bezel

The procedure to remove the front bezel with and without the LCD panel is the same.

### Prerequisite

Follow the safety guidelines listed in [Safety instructions](#).

### Steps

1. Unlock the bezel by using the bezel key.
2. Press the release button, and pull the left end of the bezel.
3. Unhook the right end, and remove the bezel.

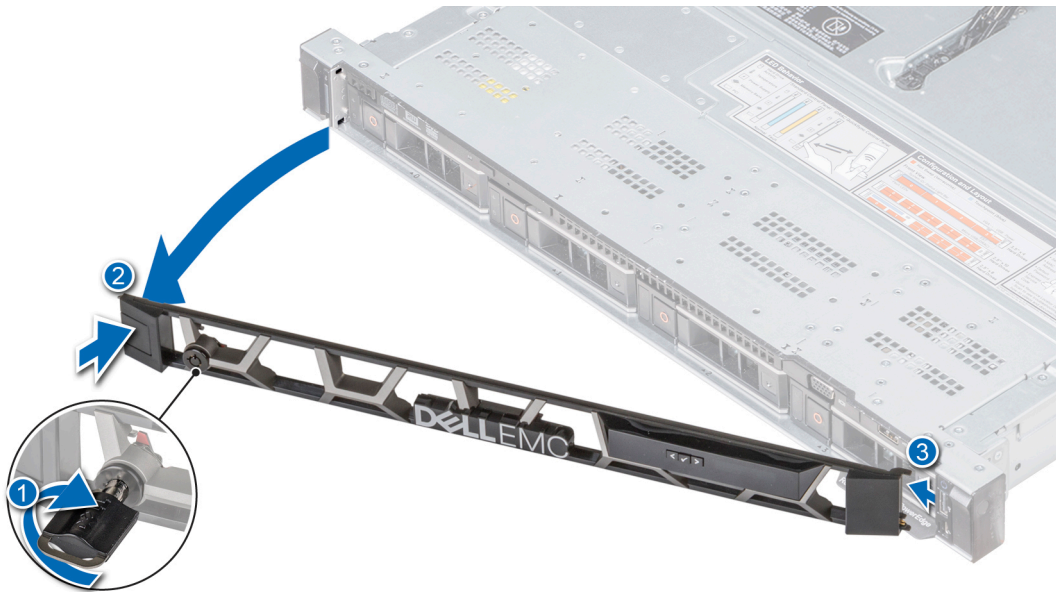

Figure 19. Removing the front bezel with the LCD panel

## Installing the front bezel

The procedure to install the front bezel with and without the LCD panel is the same.

### Prerequisites

- 1 Follow the safety guidelines listed in [Safety instructions](#).
- 2 If applicable, locate and remove the key from the inside of the bezel.

**NOTE:** The bezel key is part of the bezel package.

### Steps

- 1 Align and insert the right end of the bezel onto the system.
- 2 Press the release button and fit the left end of the bezel onto the system.
- 3 Lock the bezel by using the key.

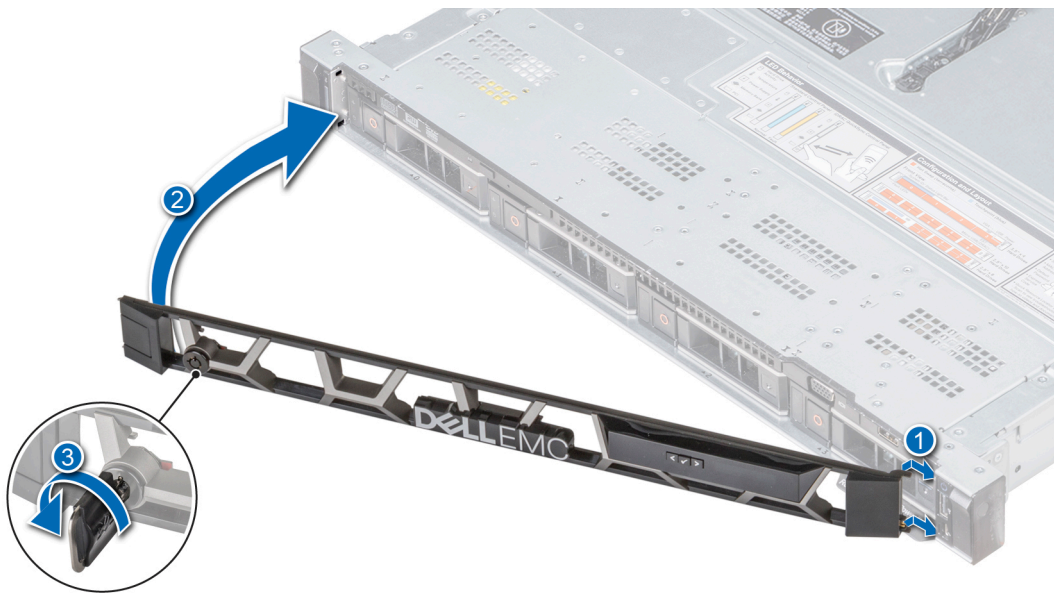

Figure 20. Installing the front bezel with the LCD panel

## System cover

System cover provides security for the entire system and also helps in maintaining proper air flow inside the system.

## Removing the system cover

### Prerequisites

- 1 Follow the safety guidelines listed in [Safety instructions](#).
- 2 Turn off the system, and all the attached peripherals in the requisite order.
- 3 Disconnect the system from the electrical outlet and disconnect the peripherals.

### Steps

- 1 Using a 1/4 inch flat head or a Phillips #2 screwdriver, rotate the latch release lock counter clockwise to the unlocked position.
- 2 Lift the latch till the system cover slides back and the tabs on the system cover disengage from the guide slots on the system.
- 3 Hold the cover on both sides, and lift the cover away from the system.

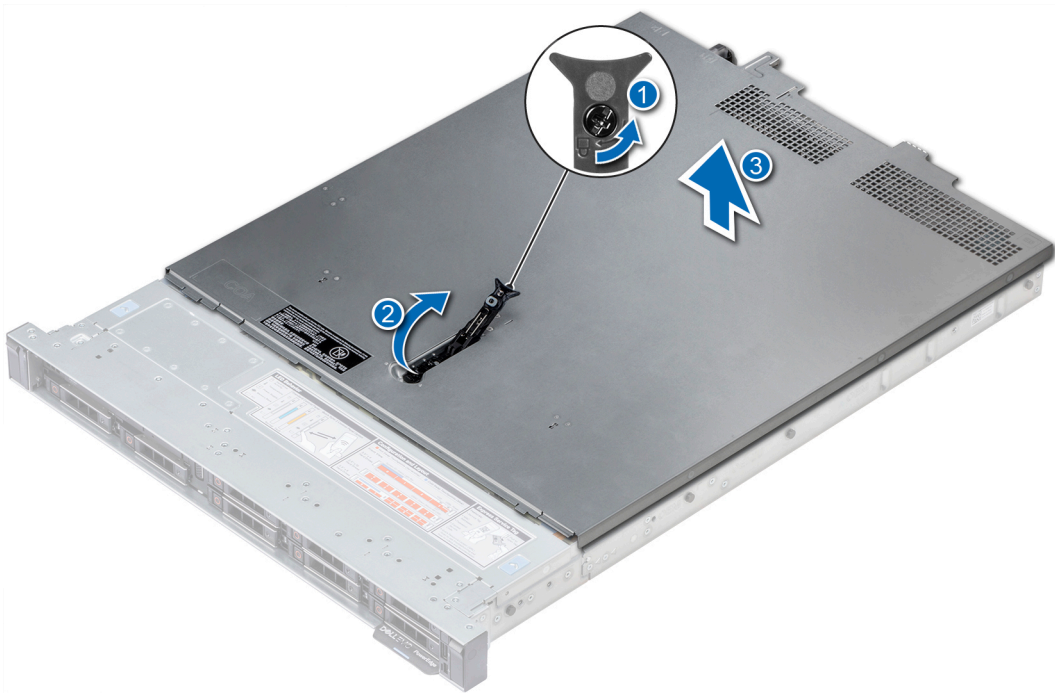

**Figure 21. Removing the system cover**

**Next step**

Install the system cover. For more information, see [Installing the system cover](#).

## Installing the system cover

**Prerequisites**

- 1 Follow the safety guidelines listed in [Safety instructions](#).
- 2 Ensure that all internal cables are routed correctly and connected, and no tools or extra parts are left inside the system.

**Steps**

- 1 Align the tabs on the system cover with the guide slots on the system.
- 2 Push the system cover latch down.  
The system cover slides forward, the tabs on the system cover engage with the guide slots on the system and the system cover latch locks into place.
- 3 Using a 1/4 inch flat head or Phillips #2 screwdriver, rotate the latch release lock clockwise to the locked position.



**Figure 22. Installing system cover**

#### **Next steps**

- 1 Reconnect the peripherals and connect the system to the electrical outlet.
- 2 Turn on all the attached peripherals and the system, in the requisite order.

## **Backplane cover**

### **Removing the backplane cover**

#### **Prerequisites**

- 1 Follow the safety guidelines listed in [Safety instructions](#).
- 2 Follow the procedure listed in [Before working inside your system](#).

#### **Steps**

- 1 Slide the backplane cover in the direction of the arrows marked on the backplane cover.
- 2 Lift the backplane cover away from the system.

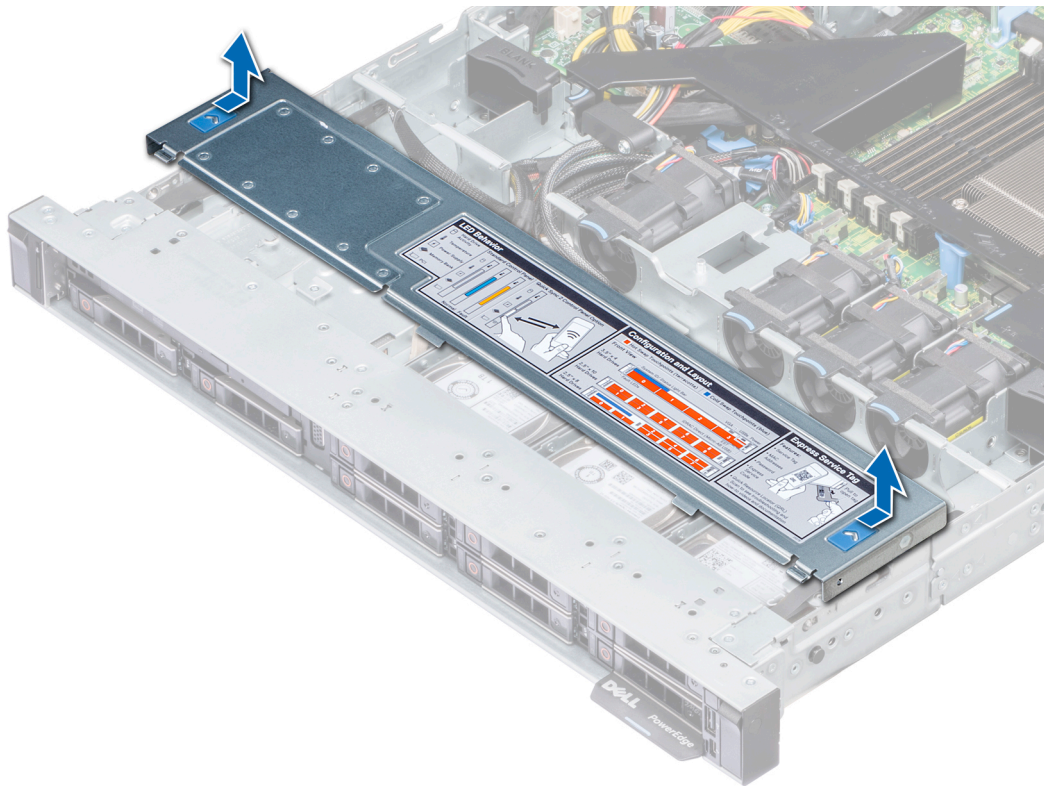

Figure 23. Removing backplane cover

**Next step**

Install the backplane cover. For more information see, [Installing the backplane cover](#).

## Installing the backplane cover

**Prerequisite**

Follow the safety guidelines listed in [Safety instructions](#).

**Steps**

- 1 Align the backplane cover with the guide slots on the system.
- 2 Slide the backplane cover toward the front of the system until the cover locks into place.

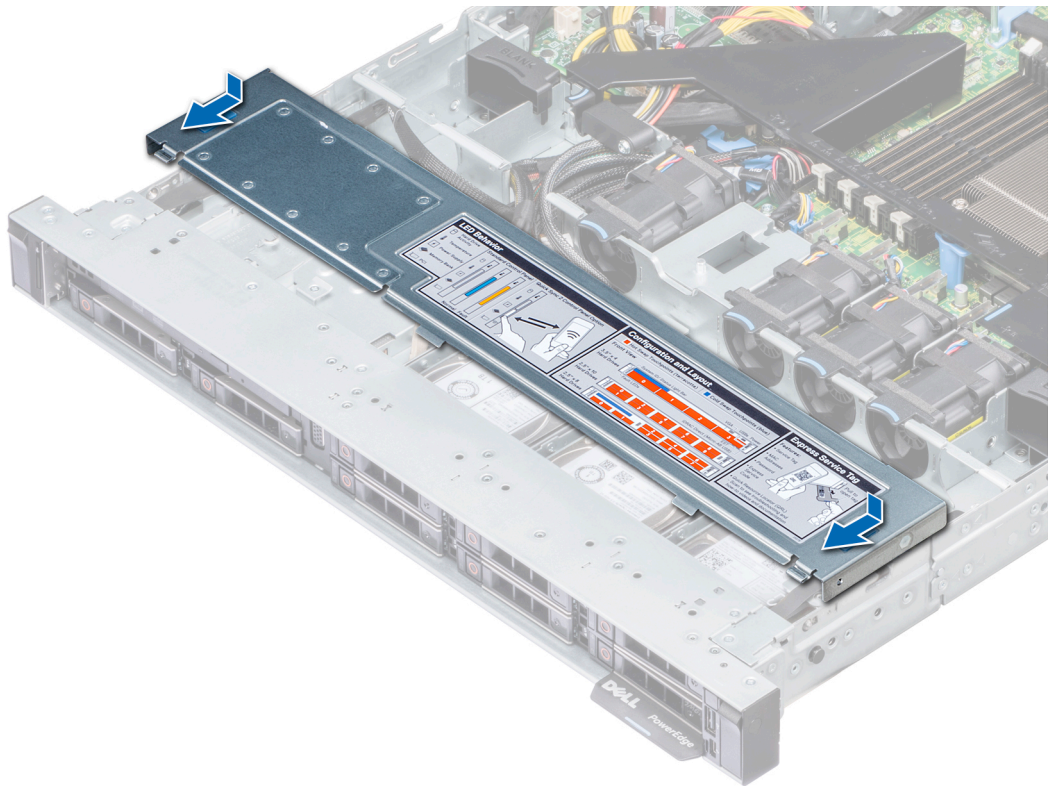

Figure 24. Installing backplane cover

#### Next step

Follow the procedure listed in [After working inside your system.](#)

## Inside the system

**NOTE:** Components with orange touch points are hot swappable and components are not hot swappable have blue touch points.

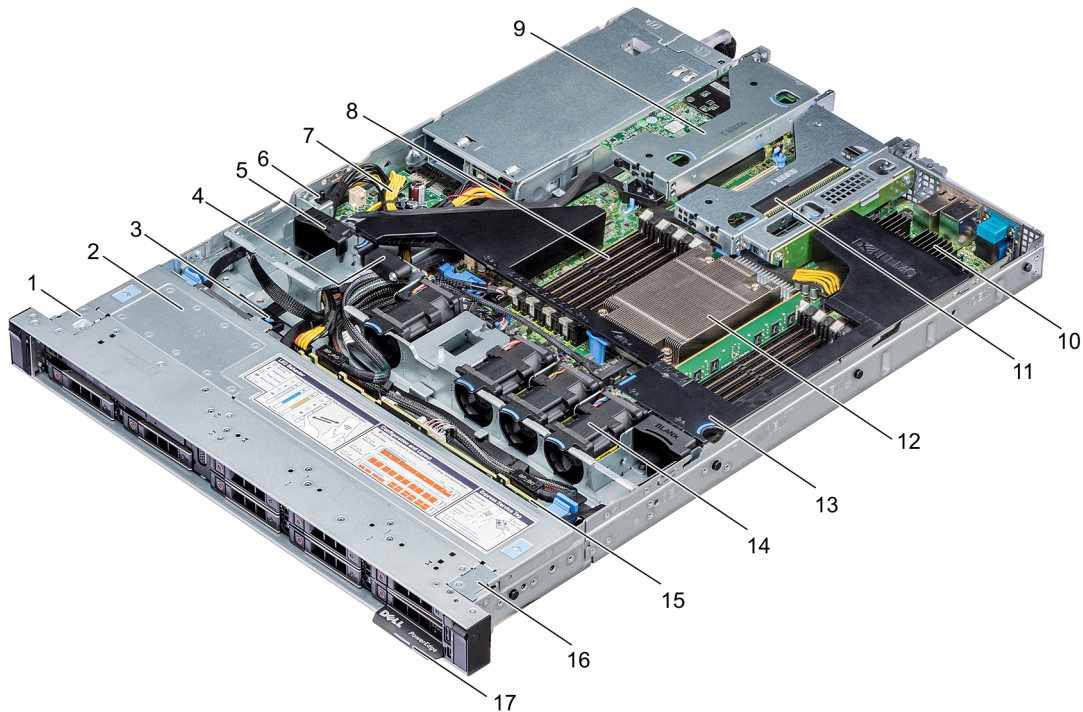

**Figure 25. Inside the system**

- |    |                           |    |                       |
|----|---------------------------|----|-----------------------|
| 1  | left ear                  | 2  | backplane cover       |
| 3  | optical drive release tab | 4  | cable retention latch |
| 5  | fan blank                 | 6  | intrusion switch      |
| 7  | power interposer board    | 8  | memory module slots   |
| 9  | low profile riser left    | 10 | mini PERC card        |
| 11 | low profile riser right   | 12 | CPU                   |
| 13 | air shroud                | 14 | cooling fans          |
| 15 | drive backplane           | 16 | right ear             |
| 17 | information tag           |    |                       |

## Air shroud

The air shroud directs the airflow across the entire system. Air shroud prevents the system from overheating and is used to maintain uniform airflow inside the system.

## Removing the air shroud

### Prerequisites

**⚠ CAUTION: Never operate your system with the air shroud removed. The system may get overheated quickly, resulting in shutdown of the system and loss of data.**

- 1 Follow the safety guidelines listed in [Safety instructions](#).
- 2 Follow the procedure listed in [Before working inside your system](#).

### Step

Hold the air shroud touch points at both ends and lift the shroud out of the system.

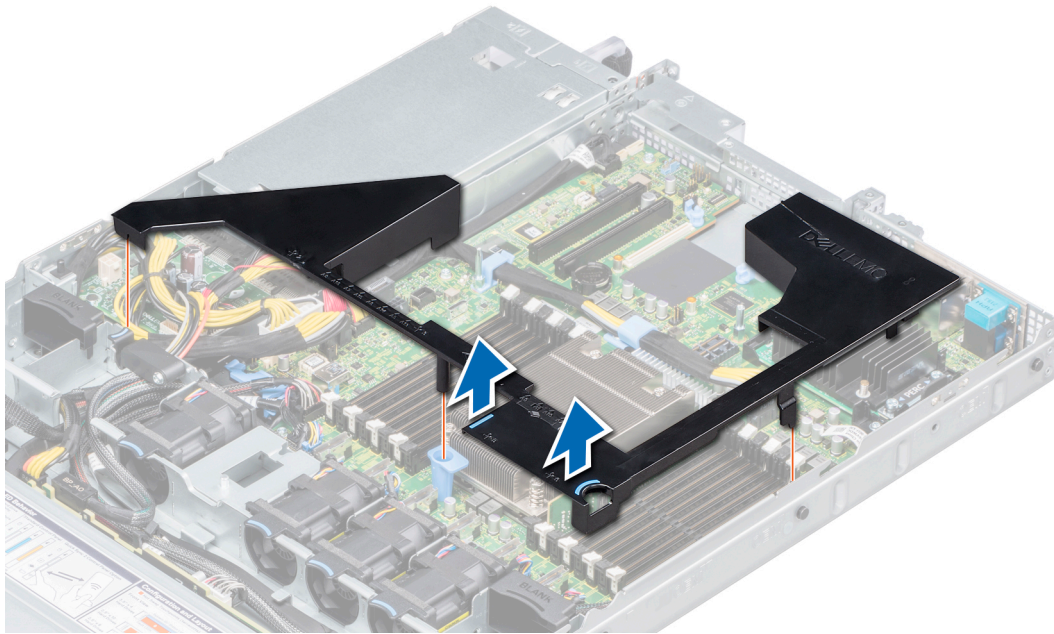

**Figure 26. Removing the air shroud**

**Next step**

Install the air shroud. For more information see, [Installing the air shroud](#).

## Installing the air shroud

**Prerequisite**

Follow the safety guidelines listed in [Safety instructions](#).

**Steps**

- 1 Align the tabs on the air shroud with the slots on the system.
- 2 Lower the air shroud into the system until it is firmly seated.

When installed, the memory socket numbers indicated on the air shroud align with the respective memory sockets on the system board.

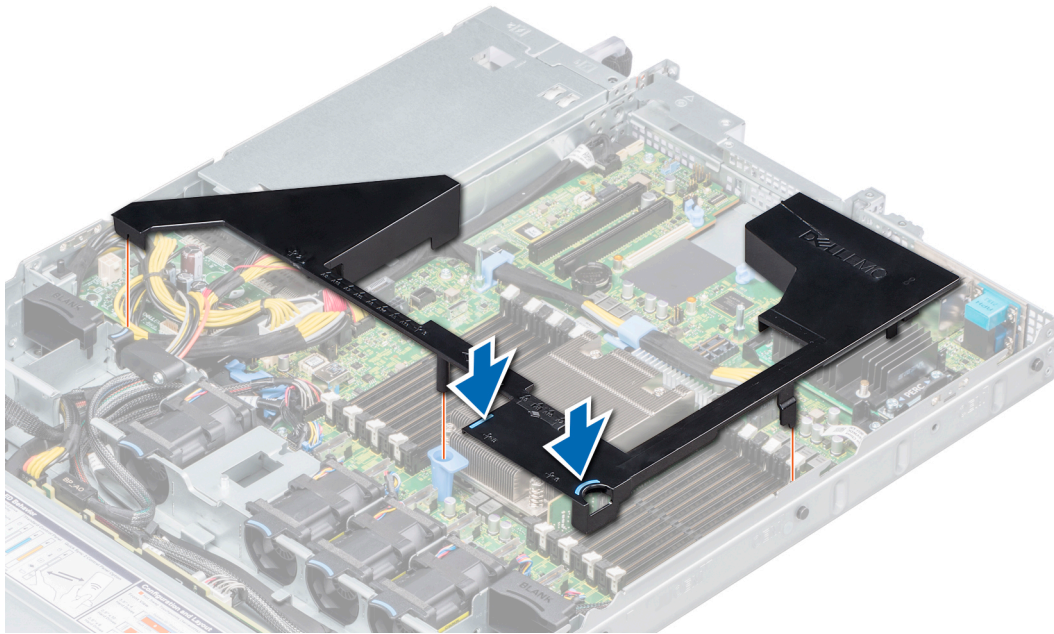

**Figure 27. Installing the air shroud**

#### **Next step**

Follow the procedure listed in [After working inside your system](#).

## Cooling fans

The cooling fans are integrated into the system to dissipate the heat generated by the functioning of the system. These fans provide cooling for the processors, expansion cards, and memory modules.

Your system supports up to six standard cabled cooling fans.

## Removing a cooling fan

#### **Prerequisites**

- 1 Follow the safety guidelines listed in [Safety instructions](#).
- 2 Follow the procedure listed in [Before working inside your system](#).
- 3 Remove the air shroud. For more information see, [Removing the air shroud](#).
- 4 Move the cables out of way to access the cooling fan cable connector on the system board.

#### **Steps**

- 1 Disconnect the cooling fan cable connected to the system board connector.
- 2 Holding the blue tab, lift the cooling fan out of the fan cage.

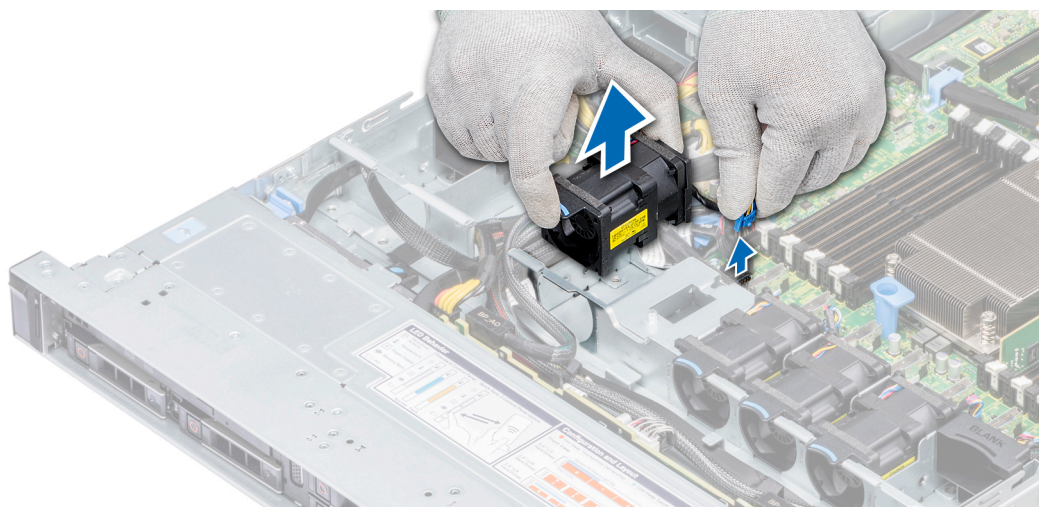

Figure 28. Removing a cooling fan

#### Next step

Install the cooling fan. For more information, see [Installing a cooling fan](#).

## Installing a cooling fan

#### Prerequisite

**⚠ WARNING:** Opening or removing the system cover when the system is on may expose you to a risk of electric shock. Exercise utmost care while removing or installing cooling fans.

Follow the safety guidelines listed in [Safety instructions](#).

#### Steps

- 1 Holding the blue touch point, place the cooling fan into the fan cage.
- 2 Route the fan cable and connect it to the connector on the system board.

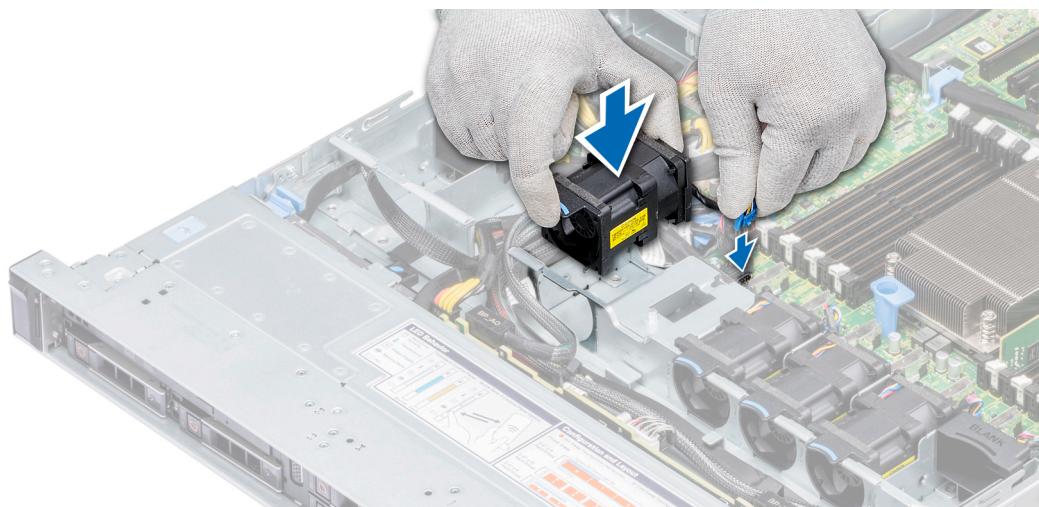

Figure 29. Installing a cooling fan

### Next steps

- 1 Install the air shroud. For more information see, [Installing the air shroud](#).
- 2 Follow the procedure listed in [After working inside your system](#).

## Intrusion switch

The chassis intrusion detection switch detects any intrusion into the system and creates a log entry in the system event log (SEL). This switch is activated when the cover of your system is removed.

## Removing the intrusion switch

### Prerequisites

- 1 Follow the safety guidelines listed in [Safety instructions](#).
- 2 Follow the procedure listed in [Before working inside your system](#).
- 3 Remove air shroud. For more information see, [Removing the air shroud](#).

### Steps

- 1 Disconnect the intrusion switch cable connected to the system board.
- 2 Slide the intrusion switch out of the intrusion switch slot.

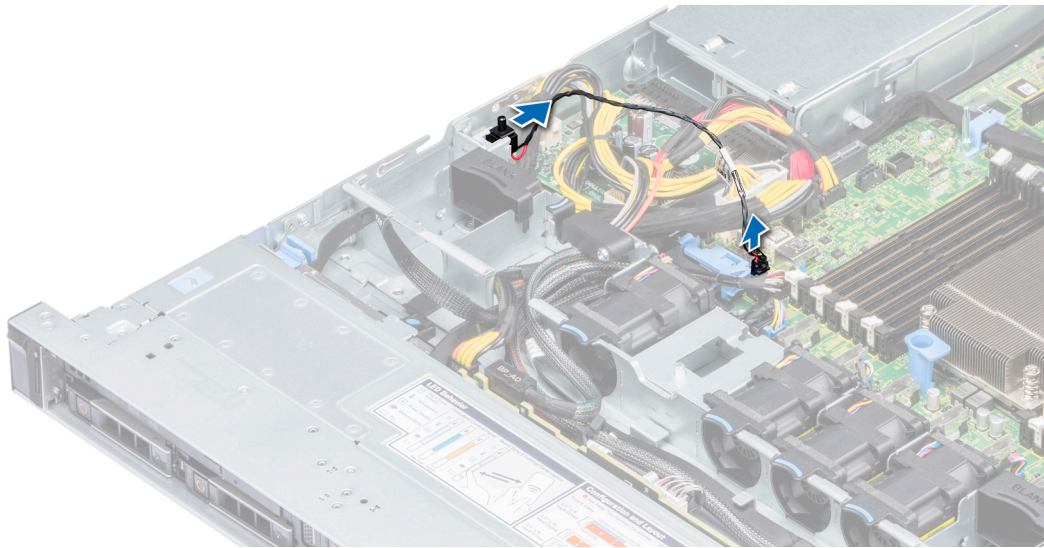

Figure 30. Removing the intrusion switch

### Next step

Installing the intrusion switch. For more information see [Installing the intrusion switch](#).

## Installing the intrusion switch

### Prerequisite

Follow the safety guidelines listed in [Safety instructions](#).

### Steps

- 1 Align the intrusion switch with the intrusion switch slot.
- 2 Slide the intrusion switch until it is firmly seated in the slot.

- 3 Connect the intrusion switch cable to the connector on the system board.

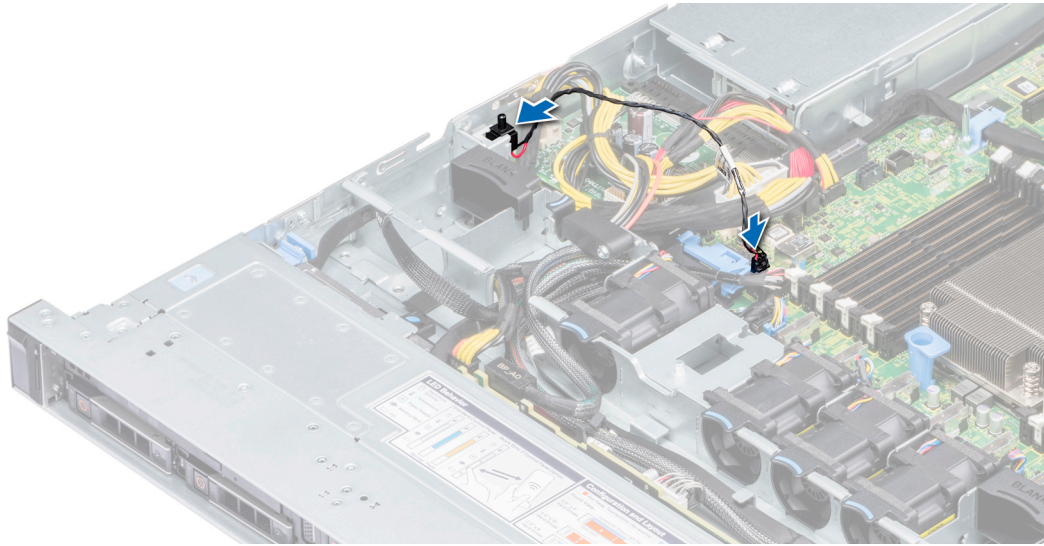

**Figure 31. Installing the intrusion switch**

#### Next steps

- 1 Install air shroud. For more information see [Installing the air shroud](#).
- 2 Follow the procedure listed in [After working inside your system](#).

## Drives

Drives are supplied in hot swappable drive carriers that fit in the drive slots.

**CAUTION:** Before attempting to remove or install a drive while the system is running, see the documentation for the storage controller card to ensure that the host adapter is configured correctly.

**CAUTION:** Do not turn off or restart your system while a drive is being formatted. Doing so can cause a drive failure.

When you format a drive, allow enough time for the formatting to complete. Be aware that high-capacity drives can take a long time to format.

## Removing a drive blank

The procedure for removing 2.5 inch and 3.5 inch drive blanks is identical.

#### Prerequisites

- 1 Follow the safety guidelines listed in [Safety instructions](#).
- 2 If installed remove the front bezel. For more information, see [Removing the front bezel](#).

**CAUTION:** To maintain proper system cooling, drive blanks must be installed in all empty drive slots.

**CAUTION:** Mixing drive blanks from previous generations of PowerEdge servers is not supported.

#### Step

Press the release button, and slide the drive blank out of the drive slot.

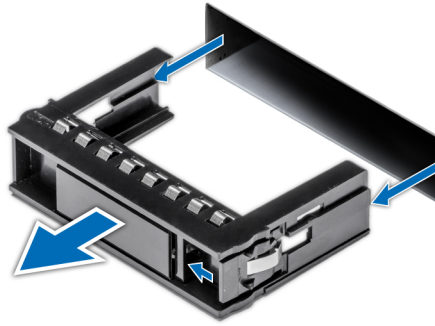

Figure 32. Removing a drive blank

#### Next step

- 1 Install a drive blank or a drive carrier. For more information, see [Installing a drive blank](#) or [Installing a drive carrier](#).

## Installing a drive blank

The procedure for installing 2.5 inch and 3.5 inch drive blanks is identical.

#### Prerequisite

Follow the safety guidelines listed in [Safety instructions](#).

**⚠ CAUTION:** Mixing drive blanks from previous generations of PowerEdge servers is not supported.

#### Step

Insert the drive blank into the drive slot, and push the blank until the release button clicks into place.

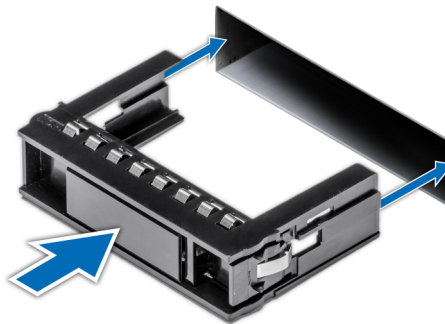

Figure 33. Installing a drive blank

#### Next step

If removed, install the front bezel. For more information, see [Installing the front bezel](#).

## Removing a drive carrier

#### Prerequisites

**⚠ WARNING:** Hot swap for NVMe drives is currently not supported for your system. Ensure that you turn off the system before installing or removing the NVMe drives.

- 1 Follow the safety guidelines listed in [Safety instructions](#).
- 2 If installed remove the front bezel. For more information, see [Removing the front bezel](#).
- 3 Using the management software, prepare the drive for removal.

If the drive is online, the green activity or fault indicator flashes while the drive is turning off. When the drive indicators are off, the drive is ready for removal. For more information, see the documentation for the storage controller.

- ⚠ **CAUTION:** Before attempting to remove or install a drive while the system is running, see the documentation for the storage controller card to ensure that the host adapter is configured correctly to support drive removal and insertion.
- ⚠ **CAUTION:** Mixing drives from previous generations of PowerEdge servers is not supported.
- ⚠ **CAUTION:** To prevent data loss, ensure that your operating system supports drive installation. See the documentation supplied with your operating system.

### Steps

- 1 Press the release button to open the drive carrier release handle.
- 2 Holding the handle, slide the drive carrier out of the drive slot.



Figure 34. Removing a drive carrier

### Next steps

- 1 Install the drive carrier. For more information, see [Installing a drive carrier](#).
- 2 If you are not replacing the drive immediately, install a drive blank in the empty drive slot to maintain proper system cooling. For more information, see [Installing a drive blank](#).

## Installing a drive carrier

### Prerequisites

- ⚠ **WARNING:** Hot swap for NVMe drives is currently not supported for your system. Ensure that you turn off the system before installing or removing the NVMe drives.
- ⚠ **CAUTION:** Before attempting to remove or install a drive while the system is running, see the documentation for the storage controller card to ensure that the host adapter is configured correctly to support drive removal and insertion.
- ⚠ **CAUTION:** Mixing drives from previous generations of PowerEdge servers is not supported.

- △ **CAUTION:** Combining SAS and SATA drives in the same RAID volume is not supported.
- △ **CAUTION:** When installing a drive, ensure that the adjacent drives are fully installed. Inserting a drive carrier and attempting to lock its handle next to a partially installed carrier can damage the partially installed carrier's shield spring and make it unusable.
- △ **CAUTION:** To prevent data loss, ensure that your operating system supports hot-swap drive installation. See the documentation supplied with your operating system.
- △ **CAUTION:** When a replacement hot swappable drive is installed and the system is powered on, the drive automatically begins to rebuild. Ensure that the replacement drive is blank or contains data that you wish to overwrite. Any data on the replacement drive is immediately lost after the drive is installed.

Follow the safety guidelines listed in [Safety instructions](#).

### Steps

- 1 Press the release button on the front of the drive carrier to open the release handle.
- 2 Insert the drive carrier into the drive slot and slide until the drive connects with the backplane.
- 3 Close the drive carrier release handle to lock the drive in place.



Figure 35. Installing a drive carrier

### Next step

If removed install the front bezel. For more information, see [Installing the front bezel](#).

## Removing the drive from the drive carrier

### Prerequisite

Follow the safety guidelines listed in [Safety instructions](#).

- △ **CAUTION:** Mixing drives from previous generations of PowerEdge servers is not supported.

### Steps

- 1 Using Phillips #1 screwdriver, remove the screws from the slide rails on the drive carrier.
- 2 Lift the drive out of the drive carrier.



**Figure 36. Removing the drive from the drive carrier**

**Next step**

Install a hard drive into the drive carrier. For more information, see [Installing a drive into the drive carrier](#).

## Installing a drive into the drive carrier

**Prerequisites**

Follow the safety guidelines listed in [Safety instructions](#).

**⚠ CAUTION:** Mixing drive carriers from other generations of PowerEdge servers is not supported.

**📌 NOTE:** When securing a drive to the drive carrier, ensure that the screws are torqued to 4 in-lbs.

**Steps**

- 1 Insert the drive into the drive carrier with the connector end of the drive towards the back of the carrier.
- 2 Align the screw holes on the drive with the screws holes on the drive carrier.  
When aligned correctly, the back of the drive is flush with the back of the drive carrier.
- 3 Using the Phillips #1 screwdriver, secure the drive to the carrier with screws.



Figure 37. Installing a drive into the drive carrier

## System memory

The PowerEdge R6415 supports sixteen DDR4 registered DIMMs (RDIMMs) and load reduced DIMMs (LRDIMMs) .

**NOTE:** MT/s indicates DIMM speed in MegaTransfers per second.

Memory bus operating frequency can be 2666 MT/s, 2400 MT/s, 2133 MT/s, or 1866 MT/s depending on the following factors:

- DIMM type (RDIMM or LRDIMM)
- Number of DIMM slots populated per channel
- Maximum supported DIMM frequency of the processors

**NOTE:** For optimal performance, populate one DIMM per channel with DDR4-2666 memory modules on the first slot of each memory channel. The first slot of each channel can be identified as the DIMM slots with white latches. For example, 64 GB system memory capacity can be divided into 8 x 8 GB DIMM slots.

Table 39. Supported memory matrix

DIMM type	Rank	Capacity	DIMM rated voltage and speed	Operating Speed	
				1 DPC	2 DPC
RDIMM	1R	8GB	DDR4 (1.2V), 2666 MT/s	2400 MT/s	1866 MT/s
RDIMM	2R	16GB , 32GB	DDR4 (1.2V), 2666 MT/s	2400 MT/s	1866 MT/s
LRDIMM	4R	64GB	DDR4 (1.2V), 2666 MT/s	2666MT/s	2133 MT/s

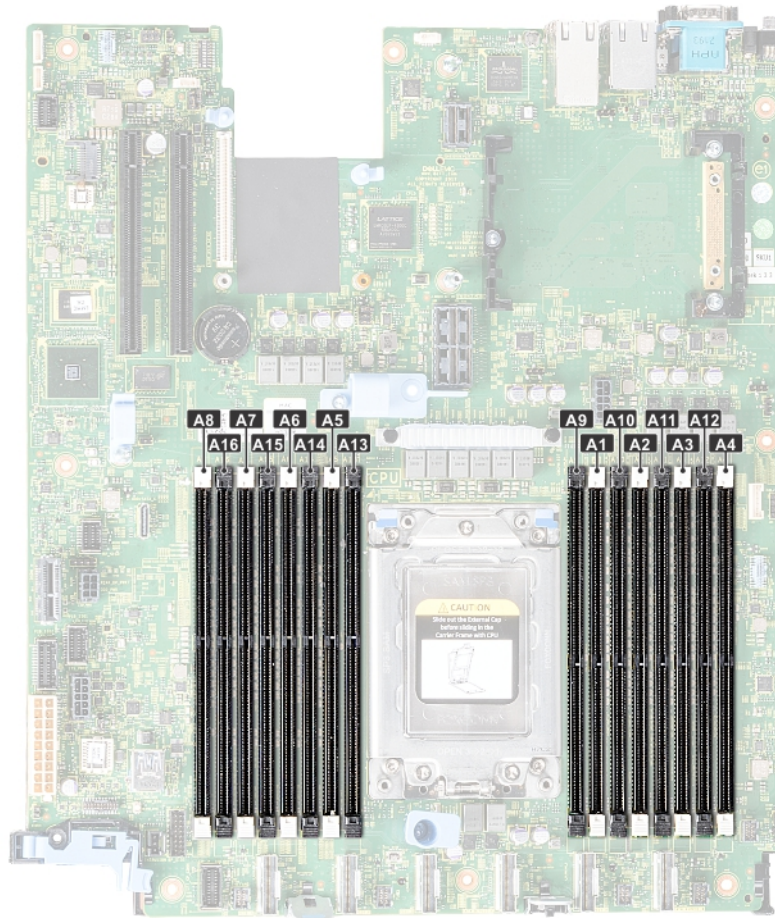

**Figure 38. Memory socket location**

Memory channels are organized as follows:

**Table 40. Memory channels**

Processor	Channel 0	Channel 1	Channel 2	Channel 3	Channel 4	Channel 5	Channel 6	Channel 7
AMD Processor	A1	A2	A3	A4	A5	A6	A7	A8
	A9	A10	A11	A12	A13	A14	A15	A16

## General memory module installation guidelines

**NOTE:** If your system's memory configurations fail to observe these guidelines, your system might not boot, might stop responding during memory configuration, or might operate with reduced memory.

The system supports Flexible Memory Configuration, enabling the system to be configured and run in any valid chipset architectural configuration. The following are the recommended guidelines for installing memory modules:

- RDIMMs and LRDIMMs must not be mixed.
- Up to two RDIMMs can be populated per channel regardless of rank count.
- Up to two LRDIMMs can be populated per channel regardless of rank count.
- If memory modules with different speeds are installed, they will operate at the speed of the slowest installed memory module(s) or slower depending on the system DIMM configuration.

- Populate memory module sockets only if a processor is installed. For single-processor systems, sockets A1 to A16 are available.
- Populate all the sockets with white release tabs first, followed by the black release tabs.
- When mixing memory modules with different capacities, populate the sockets with memory modules with the highest capacity first. For example, if you want to mix 8 GB and 16 GB memory modules, populate 16 GB memory modules in the sockets with white release tabs and 8 GB memory modules in the sockets with black release tabs.
- Memory modules of different capacities can be mixed provided other memory population rules are followed (for example, 8 GB and 16 GB memory modules can be mixed).
- Mixing of more than two memory module capacities in a system is not supported.
- Populate eight memory modules per processor (one DIMM per channel) at a time to maximize performance.
- For optimal performance, populate one DIMM per channel with DDR4-2666 memory modules on the first slot of each memory channel. The first slot of each channel can be identified as the DIMM slots with white latches. For example, 64 GB system memory capacity can be divided into 8 x 8 GB DIMM slots.

## Mode-specific guidelines

Eight memory channels are allocated to the processor. The configurations allowed depends on the memory mode selected.

### Memory optimized (independent channel) mode

This mode supports Single Device Data Correction (SDDC) only for memory modules that use x4 device width. It does not impose any specific slot population requirements.

## Removing a memory module

### Prerequisites

- 1 Follow the safety guidelines listed in [Safety instructions](#).
- 2 Follow the procedure listed in [Before working inside your system](#).
- 3 Remove the air shroud. For more information, see [Removing the air shroud](#).

**⚠ WARNING:** Allow the memory modules to cool after you power off the system. Handle the memory modules by the card edges and avoid touching the components or metallic contacts on the memory module.

**⚠ CAUTION:** To ensure proper system cooling, memory module blanks must be installed in any memory socket that is not occupied. Remove memory module blanks only if you intend to install memory modules in those sockets.

### Steps

- 1 Locate the appropriate memory module socket.

**⚠ CAUTION:** Handle each memory module only by the card edges, ensuring not to touch the middle of the memory module or metallic contacts.

- 2 Push the ejectors outward on both ends of the memory module socket to release the memory module from the socket.
- 3 Lift and remove the memory module from the system.

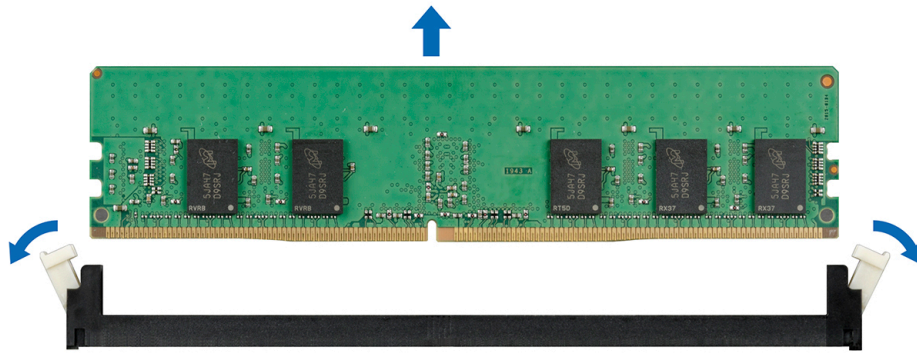

Figure 39. Removing a memory module

### Next steps

- 1 Install a memory module. For more information, see [Installing a memory module](#).
- 2 If you are removing the memory module permanently, install a memory module blank. The procedure to install a memory module blank is similar to that of the memory module.

## Installing a memory module

### Prerequisite

Follow the safety guidelines listed in [Safety instructions](#).

### Steps

- 1 Locate the appropriate memory module socket. For more information, see [System board jumpers and connectors](#).
  - ⚠ **CAUTION:** Handle each memory module only by the card edges, ensuring not to touch the middle of the memory module or metallic contacts.
  - ⚠ **CAUTION:** To prevent damage to the memory module or the memory module socket during installation, do not bend or flex the memory module. You must insert both ends of the memory module simultaneously.
- 2 Open the ejectors on the memory module socket outward to allow the memory module to be inserted into the socket.
- 3 Align the edge connector of the memory module with the alignment key of the memory module socket, and insert the memory module in the socket.
  - ⚠ **CAUTION:** Do not apply pressure at the center of the memory module; apply pressure at both ends of the memory module evenly.
  - ℹ **NOTE:** The memory module socket has an alignment key that enables you to install the memory module in the socket in only one orientation.
- 4 Press the memory module with your thumbs until the socket levers firmly click into place.

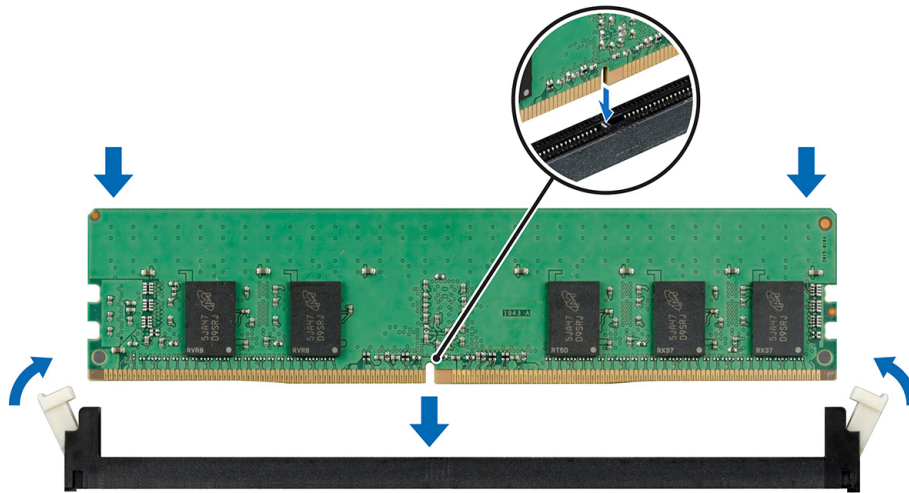

**Figure 40. Installing a memory module**

### Next steps

- 1 Install the air shroud. For more information, see [Installing the air shroud](#).
- 2 Follow the procedure listed in [After working inside your system](#).
- 3 To verify if the memory module has been installed properly, press F2 and navigate to **System Setup Main Menu > System BIOS > Memory Settings**. In the **Memory Settings** screen, the System Memory Size must reflect the updated capacity of the installed memory.
- 4 If the value is incorrect, one or more of the memory modules may not be installed properly. Ensure that the memory module is firmly seated in the memory module socket.
- 5 Run the system memory test in system diagnostics.

## Processors and heat sinks

The processor controls memory, peripheral interfaces, and other components of the system. The system can have more than one processor configurations.

The heat sink absorbs the heat generated by the processor, and helps the processor to maintain its optimal temperature level.

## Removing a heat sink

### Prerequisites

**⚠ WARNING:** The heat sink may be hot to touch for some time after the system has been powered down. Allow the heat sink to cool before removing it.

**⚠ CAUTION:** Never remove the heat sink from a processor unless you intend to remove the processor. The heat sink is necessary to maintain proper thermal conditions.

- 1 Follow the safety guidelines listed in [Safety instructions](#).
- 2 Follow the procedure listed in [Before working inside your system](#).
- 3 Remove the air shroud. For more information, see [Removing the air shroud](#).

### Steps

- 1 Using a Torx #T20 screwdriver, loosen the captive screw 4 on the heat sink.  
Allow some time (approximately 30 seconds) for the heat sink to loosen from the processor.

① **NOTE:** The captive screw numbers are marked on the heat sink.

- 2 Loosen the captive screw 3 that is diagonally opposite to the screw 4.
- 3 Repeat the procedure for the remaining two captive screws 2 and 1.
- 4 Loosen all the captive screws in the sequence 4, 3, 2, 1 and lift the heat sink away from the system.

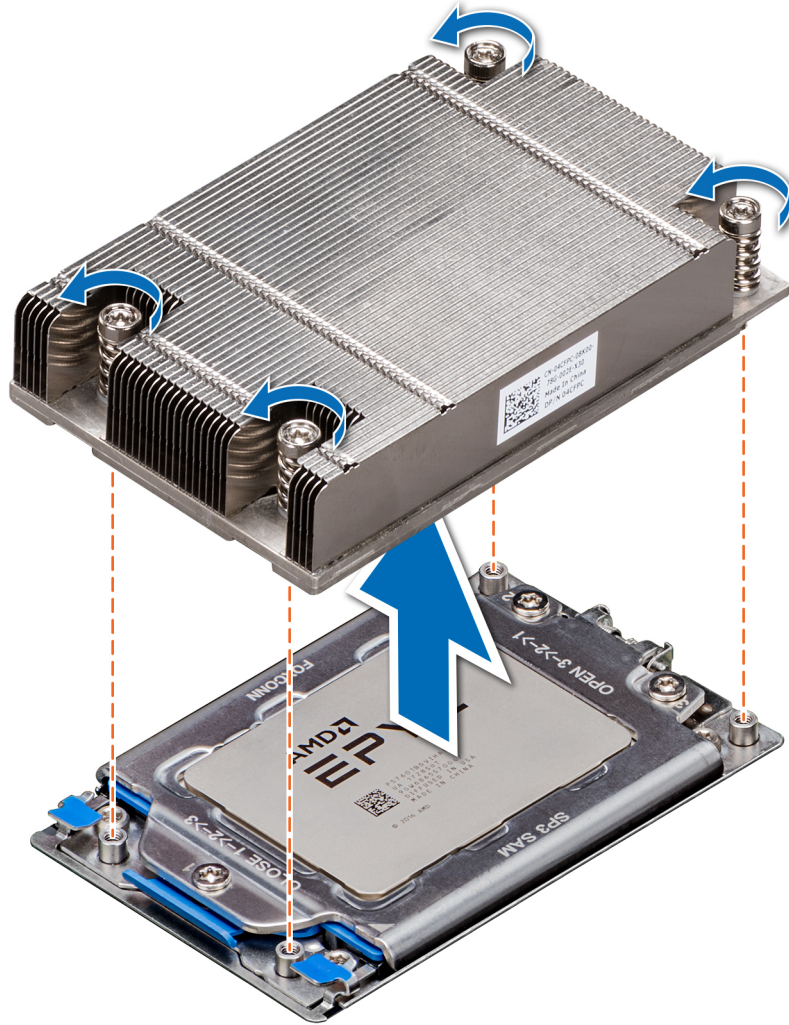

Figure 41. Removing a heat sink

#### Next step

Install the heat sink. For more information, see [Installing the heat sink](#).

## Removing the processor

#### Prerequisites

- 1 Follow the safety guidelines listed in [Safety instructions](#).
- 2 Follow the procedure listed in [Before working inside your system](#).
- 3 Remove the air shroud. For more information, see [Removing the air shroud](#).
- 4 Remove the heat sink. For more information, see [Removing a heat sink](#).

## Steps

- 1 Using a Torx #T20 screwdriver, loosen the screws to release the processor socket cover. The sequence to loosen the screws is 3, 2, and 1.

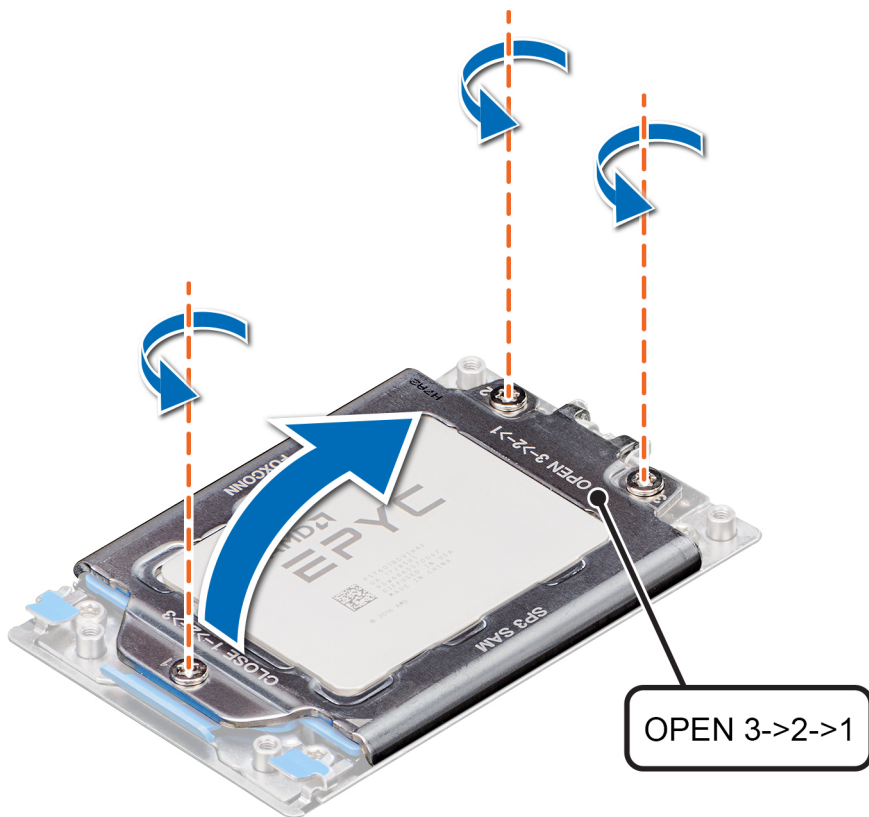

**Figure 42. Removing screws on the force plate**

- 2 Release the processor socket frame by lifting up the blue latches.



**Figure 43. Lifting the rail frame**

- 3 Holding the blue tab on the processor tray, slide the tray out of the processor socket frame.

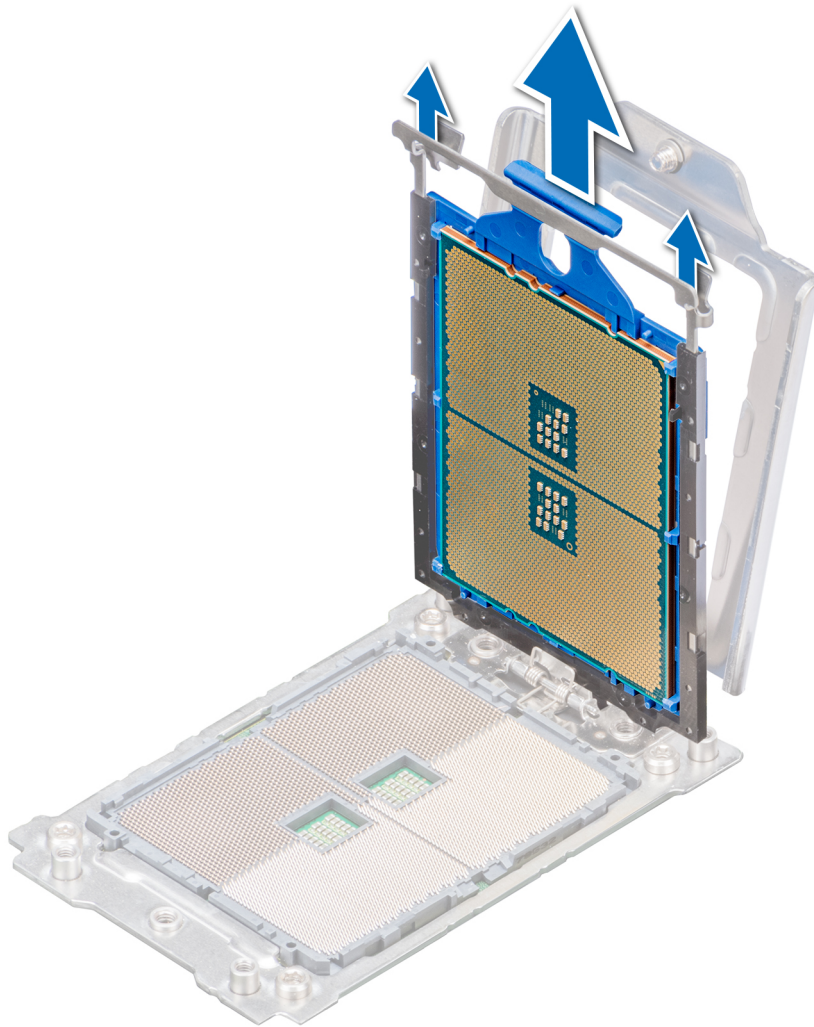

**Figure 44. Removing the processor tray**

**Next step**

Install the processor. For more information, see [Installing the processor](#).

## Installing the processor

**Prerequisite**

Follow the safety guidelines listed in [Safety instructions](#).

**Steps**

- 1 Holding the blue tab on the processor tray, slide the tray into the processor socket frame until firmly seated.

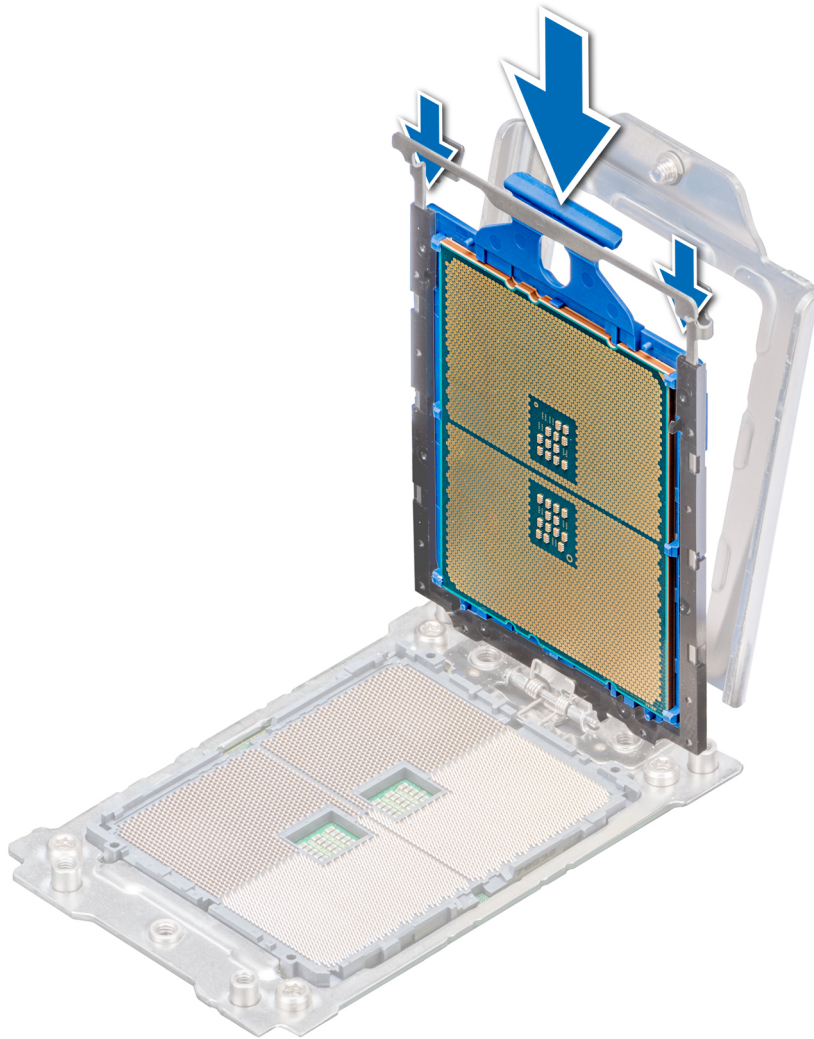

**Figure 45. Placing the processor into the processor socket frame**

- 2 Push the rail frame down until the blue latches lock into place.



**Figure 46. Closing the processor socket frame**

- 3 Secure the processor socket cover to the processor socket base by tightening the screws in the sequence 1, 2, and 3.

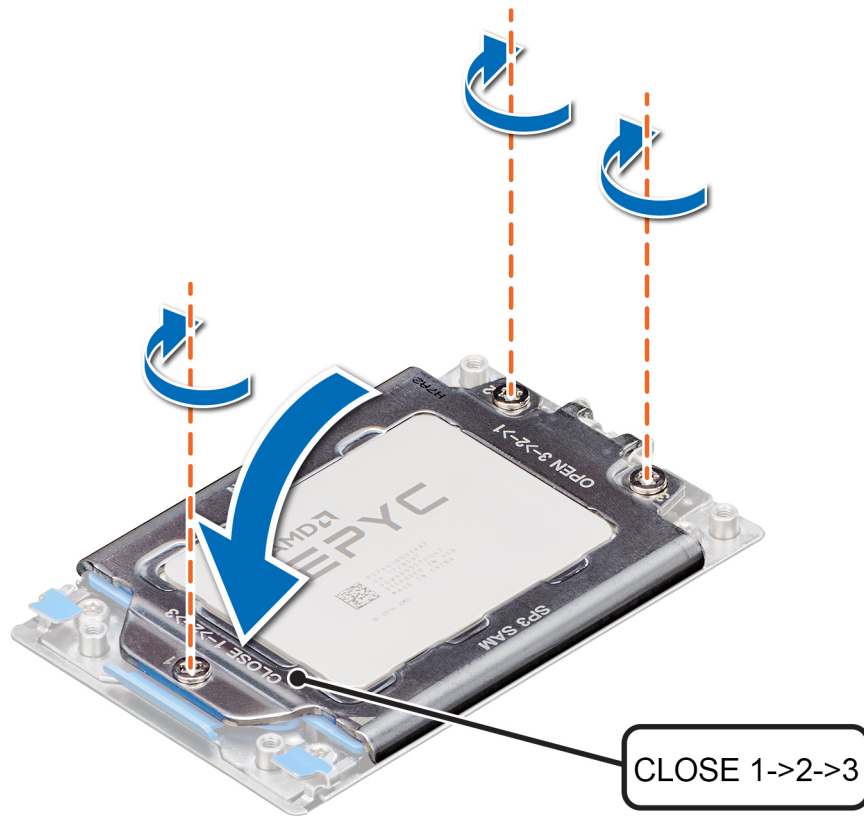

**Figure 47. Securing the processor socket cover**

#### Next steps

- 1 Install the heat sink. For more information, see [Installing the heat sink](#).
- 2 Install the air shroud. For more information, see [Installing the air shroud](#).
- 3 Follow the procedure listed in [After working inside your system](#).

## Installing the heat sink

#### Prerequisite

Follow the safety guidelines listed in [Safety instructions](#).

#### Steps

- 1 To install the heat sink, follow either of the options listed here, as applicable:
  - a If you are re-using a heat sink, remove the thermal grease from the heat sink with a clean lint free cloth.
  - b If you are using a new heat sink, the heat sink will have the thermal paste pre-applied to the heat sink. Remove the protective cover and install the heat sink.
- 2 If required, use the thermal grease syringe included with your processor kit to apply the grease on the top of the processor.

**⚠ CAUTION: Applying too much thermal grease can result in the excess grease seeping out and contaminating the processor socket.**

**📌 NOTE: The thermal grease syringe is intended for a single use only. Dispose the syringe after you use it.**

- 3 Orient the heat sink with the screw holes on the processor plate. The captive screws on the heat sink should align with the screw holes on the processor plate.

4 Using a Torx #T20 screwdriver, tighten the captive screw 1 to secure the heat sink to the system board.

① **NOTE:** The captive screw numbers are marked on the heat sink.

5 Tighten the captive screw 2 that is diagonally opposite to the screw 1.

6 Repeat the procedure for the remaining captive screws 3 and 4.

7 Tighten all the captive screws in the sequence 1, 2, 3, 4.

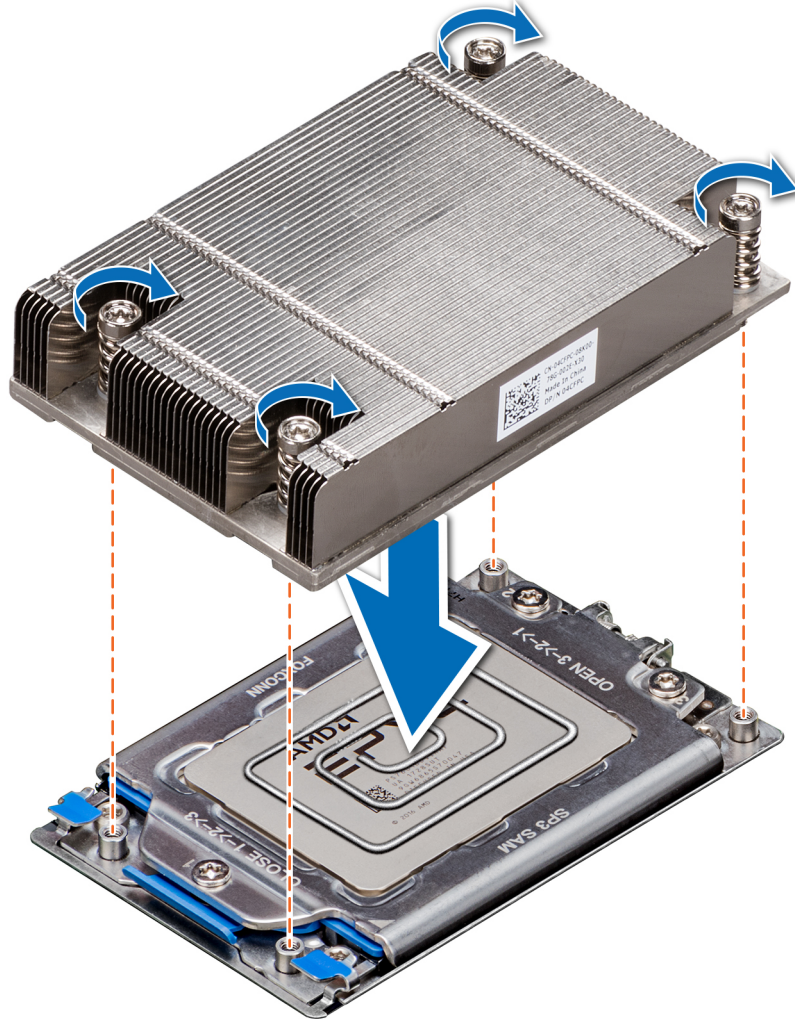

Figure 48. Installing the heat sink

#### Next steps

- 1 Install the air shroud. For more information, see [Installing the air shroud](#).
- 2 Follow the procedure listed in [After working inside your system](#).

## Expansion cards and expansion card risers

An expansion card in the system is an add-on card that can be inserted into an expansion slot on the system board or a slot on a riser card to add enhanced functionality to the system through the expansion bus.

① **NOTE:** A System Event Log (SEL) event is logged if an expansion card riser is not supported or missing. It does not prevent your system from turning on. However, if F1/F2 pause occurs and an error message is displayed.

# Expansion card installation guidelines

The following table describes the supported expansion cards:

**Table 41. Expansion card riser configurations**

Expansion card riser	PCIe slots on the riser	Processor connection	Height	Length	Slot width
No riser	Slot 1	Processor 1	-	-	x8
right riser	Slot 2	Processor 1	Low Profile	Half Length	x16
left riser	Slot 3	Processor 1	Low Profile	Half Length	x16

**NOTE:** The expansion-card slots are not hot-swappable.

The following table provides guidelines for installing expansion cards to ensure proper cooling and mechanical fit. The expansion cards with the highest priority should be installed first using the slot priority indicated. All the other expansion cards should be installed in the card priority and slot priority order.

**Table 42. No riser configuration (Slot 1)**

Card type	Slot priority	Maximum number of cards
PERC9 (H330, HBA 330, H730P)	Internal Slot	1
PERC10 (H740P)	Internal Slot	1
LOM (1G/10G)	1	1

**Table 43. Riser 1 configuration (include slots 1 and 2)**

Card type	Slot priority	Maximum number of cards
PERC9 (H330, HBA 330, H730P)	Internal Slot	1
PERC10 (H740P)	Internal Slot	1
NVME PCIE SSD	2	1
Broadcom (1G DP/1G QP)	2	1
Broadcom (10G DP)	2	1
Broadcom (25G DP)	2	1
Intel 10G (BaseT DP/QP)	2	1
Intel 10G (SFP+ DP/QP)	2	1
Intel 1G (DP/QP)	2	1
Emulex (FC32 2P)	2	1
Emulex (FC16 1P)/(FC16 2P)	2	1
Emulex (FC8 SC)/(FC8 DLC)	2	1
Mellanox 10G, CXP DP SFP	2	1

Card type	Slot priority	Maximum number of cards
Mellanox 25G, CX4LX DP SFP	2	1
Qlogic 10G BASET DP	2	1
Qlogic 10G SFP+ DP	2	1
Qlogic 25G SFP DP	2	1
Qlogic (FC8 DCL)	2	1
Qlogic (FC16 SP/DP)	2	1
Qlogic (FC32 DP)	2	1
LOM ( 2x1G)/(2x10G)	1	1

**Table 44. Riser 3 configuration (include slots 1,2, and 3)**

Card type	Slot priority	Maximum number of cards
PERC9 (H330, HBA 330, H730P)	Internal Slot	1
PERC10 (H740P)	Internal Slot	1
NVME PCIE SSD	2,3	2
Broadcom (1G DP/1G QP)	2,3	2
Broadcom (10G DP)	2,3	2
Broadcom (25G DP)	2,3	2
Intel 10G (BaseT DP/QP)	2,3	2
Intel 10G (SFP+ DP/QP)	2,3	2
Intel 1G (DP/QP)	2,3	2
Emulex (FC32 2P)	2,3	2
Emulex (FC16 1P)/(FC16 2P)	2,3	2
Emulex (FC8 SC)/(FC8 DLC)	2,3	1
Mellanox 10G, CXP DP SFP	2,3	2
Mellanox 25G, CX4LX DP SFP	2,3	2
Qlogic 10G BASET DP	2,3	2
Qlogic 10G SFP+ DP	2,3	2
Qlogic 25G SFP DP	2,3	2
Qlogic (FC8 DCL)	2,3	2
Qlogic (FC16 SP/DP)	2,3	2
Qlogic (FC32)	2,3	2
LOM ( 2x1G)/(2x10G)	1	1

# Removing the expansion card risers

## Prerequisites

- 1 Follow the safety guidelines listed in [Safety instructions](#).
- 2 Follow the procedure listed in [Before working inside your system](#).
- 3 Disconnect any cables connected to the expansion card.
- 4 Remove the air shroud. For more information, see [Removing the air shroud](#).

## Step

Hold the touch points, and lift the expansion card riser, from the riser connector, on the system board.

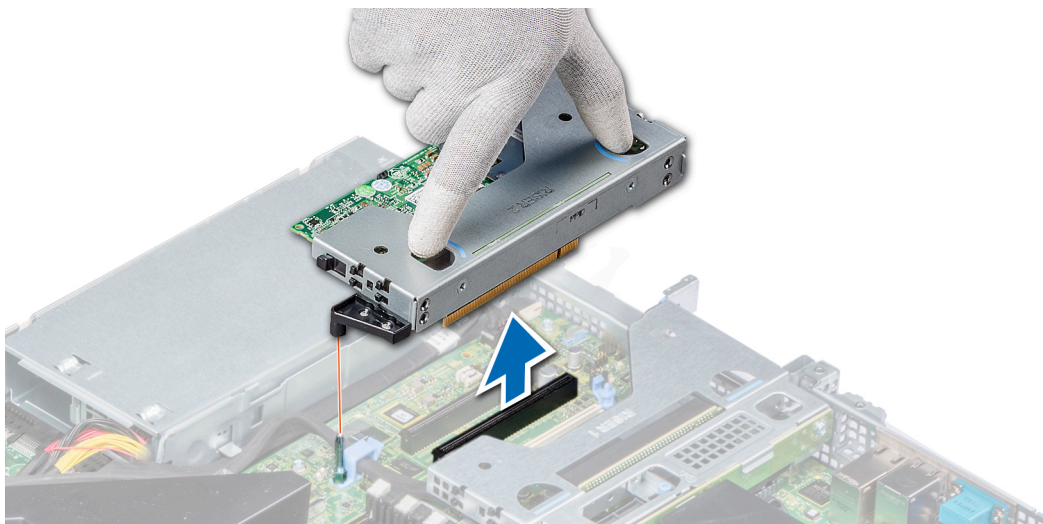

Figure 49. Removing the low profile left riser

**NOTE:** For low profile riser right, first loosen the captive screw and then holding the touch points lift the riser away from the system.

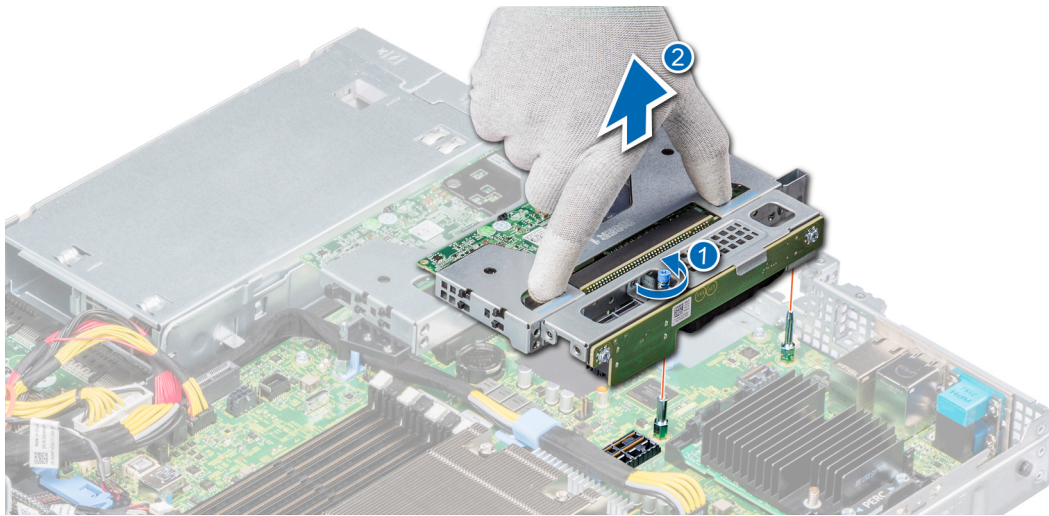

Figure 50. Removing the low profile right riser

**Next step**

Install the expansion card riser. For more information, see [Installing the expansion card risers](#).

## Installing the expansion card risers

**Prerequisites**

- 1 Follow the safety guidelines listed in [Safety instructions](#).
- 2 If removed, install the expansion cards into the expansion card risers. For more information, see [Installing an expansion card into the expansion card riser](#)

**Steps**

- 1 Holding the touch points, align the expansion card riser with the connector and the riser guide pin on the system board.
- 2 Lower the expansion card riser into place until the expansion card riser connector is fully seated in the connector.

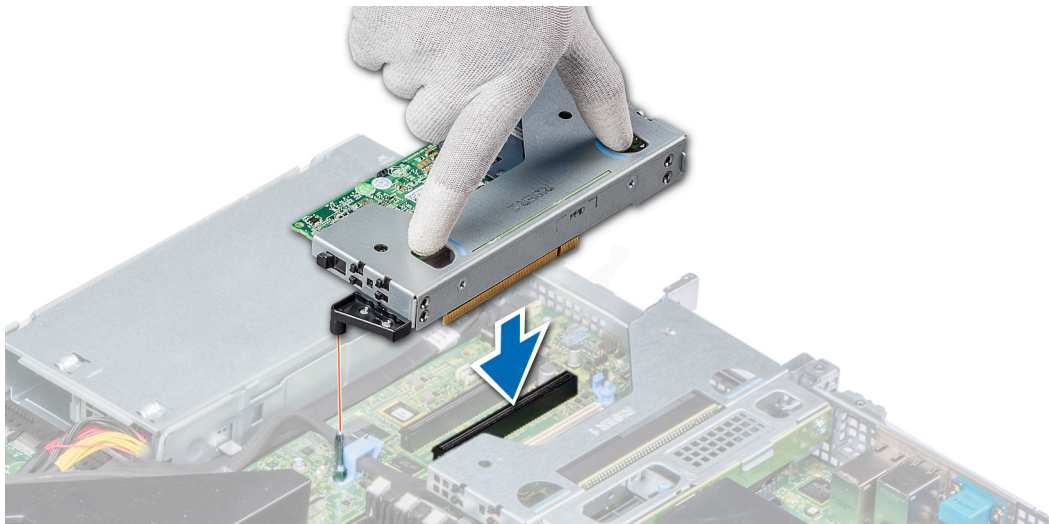
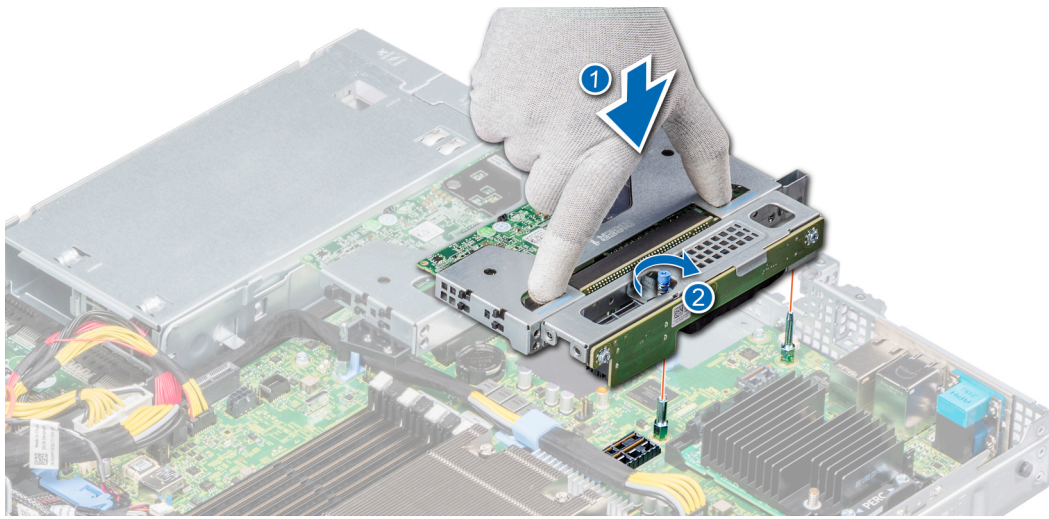

Figure 51. Installing the low profile left riser

**NOTE:** For low profile riser right, tighten the captive screw to secure the riser to the system board.



**Figure 52. Installing the low profile right riser**

#### Next steps

- 1 If required, re-connect the cables to the expansion card.
- 2 Install the air shroud. For more information, see [Installing the air shroud](#).
- 3 Follow the procedure listed in [After working inside your system](#).
- 4 Install any device drivers required for the card as described in the documentation for the card.

## Removing expansion card from the expansion card riser

#### Prerequisites

- 1 Follow the safety guidelines listed in [Safety instructions](#).
- 2 Follow the procedure listed in [Before working inside your system](#).
- 3 Remove the air shroud. For more information, see [Removing the air shroud](#).
- 4 If applicable, disconnect the cables from the expansion card.

#### Steps

- 1 Pull and lift up the expansion card retention latch lock to open.
- 2 Hold the expansion card by its edges, and pull the card until the card edge connector disengages from the expansion card connector on the riser.

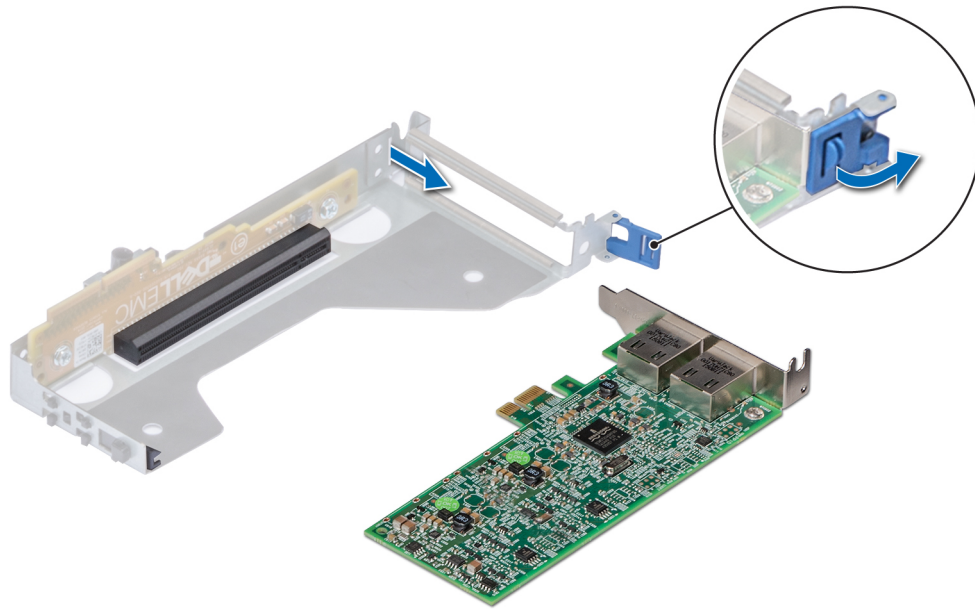

**Figure 53. Removing an expansion card from a riser**

- 3 If the expansion card is not going to be replaced, install a filler bracket and close the card retention latch.

**NOTE:** You must install a filler bracket over an empty expansion card slot to maintain Federal Communications Commission (FCC) certification of the system. The brackets also keep dust and dirt out of the system and aid in proper cooling and airflow inside the system.

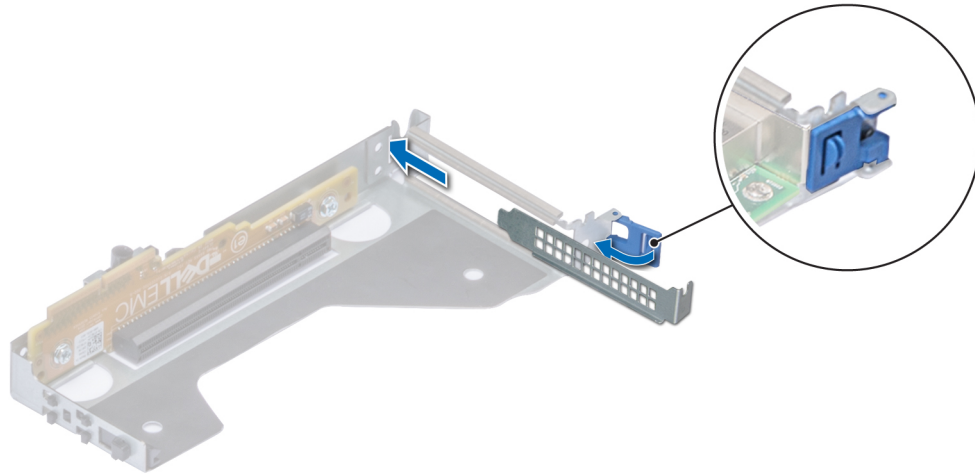

**Figure 54. Installing filler bracket for the riser**

**Next step**

If applicable, install an expansion card. For more information, see [Installing an expansion card into the expansion card riser](#).

## Installing an expansion card into the expansion card riser

**Prerequisites**

- 1 Follow the safety guidelines listed in [Safety instructions](#).
- 2 If installing a new expansion card, unpack it and prepare the card for installation.

**NOTE:** For instructions, see the documentation accompanying the card.

**Steps**

- 1 Pull and lift up the expansion card retention latch lock to open.
- 2 If installed, remove the filler bracket.

**NOTE:** Store the filler bracket for future use. Filler brackets must be installed in empty expansion card slots to maintain Federal Communications Commission (FCC) certification of the system. The brackets also keep dust and dirt out of the system and aid in proper cooling and airflow inside the system.

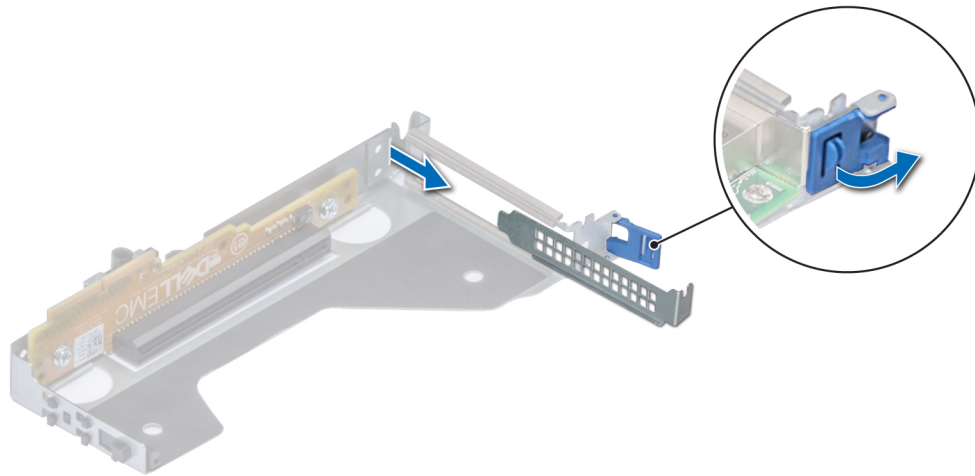

**Figure 55. Removing a filler bracket from a low profile riser**

- 3 Hold the card by its edges, and align the card edge connector with the expansion card connector on the riser.
- 4 Insert the card edge connector firmly into the expansion card connector until the card is fully seated.
- 5 Close the expansion card retention latch.

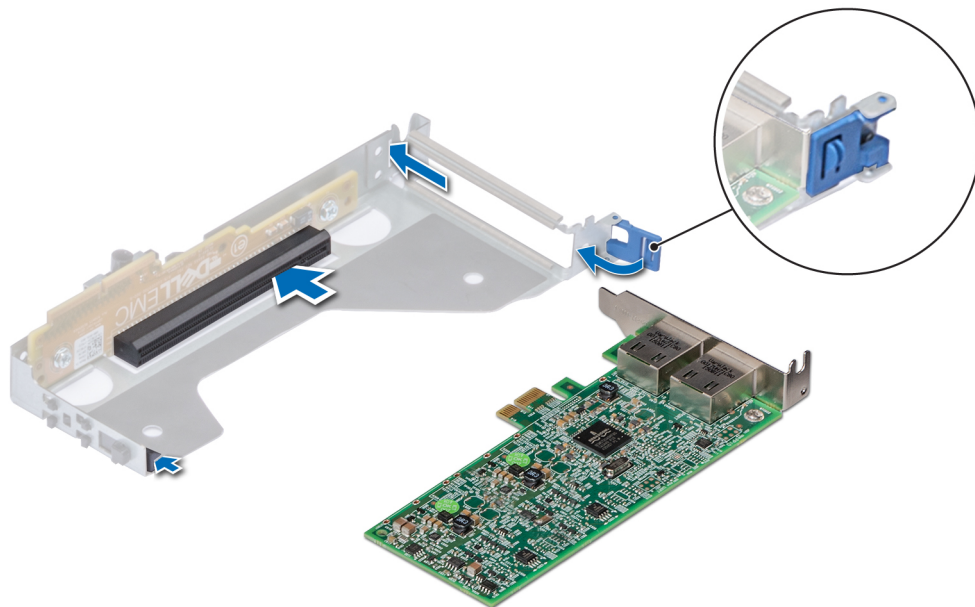

**Figure 56. Installing an expansion card into a riser**

### Next steps

- 1 If applicable, connect the cables to the expansion card.
- 2 Install the air shroud. For more information, see [Installing the air shroud](#).
- 3 Follow the procedure listed in [After working inside your system](#).
- 4 Install any device drivers required for the card as described in the documentation for the card.

## Optional IDSDM or vFlash module

The IDSDM or vFlash module combines the IDSDM or vFlash features into a single module.

**NOTE:** The write-protect switch is on the IDSDM or vFlash module.

## Removing the MicroSD card

### Prerequisites

- 1 Follow the safety guidelines listed in [Safety instructions](#).
- 2 Follow the procedure listed in [Before working inside your system](#).
- 3 Remove the air shroud. For more information, see [Removing the air shroud](#).

### Steps

- 1 Locate the MicroSD card slot on the vFlash/IDSDM module, and press the card to release it from the slot. For more information on the slot location, see [System board jumpers and connectors](#).
- 2 Hold the MicroSD card and remove it from the slot.

**NOTE:** Temporarily label each MicroSD card with its corresponding slot number after removal.

### Next step

Install the MicroSD card. For more information, see [Installing the MicroSD card](#).

## Installing the MicroSD card

### Prerequisites

Follow the safety guidelines listed in [Safety instructions](#).

**NOTE:** To use an MicroSD card with your system, ensure that the Internal SD Card Port is enabled in System Setup.

**NOTE:** Ensure that you install the MicroSD cards into the same slots based on the labels you had marked on the cards during removal.

### Steps

- 1 Locate the MicroSD card slot on the IDSDM/vFlash module. Orient the MicroSD card appropriately and insert the contact-pin end of the card into the slot.

**NOTE:** The slot is keyed to ensure correct insertion of the card.

- 2 Press the card into the slot to lock it into place.

### Next steps

- 1 Install the air shroud. For more information, see [Installing the air shroud](#).
- 2 Follow the procedure listed in [After working inside your system](#).

# Removing the IDSDM or vFlash module

## Prerequisites

- 1 Follow the safety guidelines listed in [Safety instructions](#).
- 2 Follow the procedure listed in [Before working inside your system](#).
- 3 Remove the micro SD cards if you are replacing the internal Dual SD module (IDSDM or vFlash). For more information, see [Removing the MicroSD card](#).

**NOTE:** Temporarily label each MicroSD card with its corresponding slot number after removal.

## Steps

- 1 Locate the IDSDM or vFlash connector on the system board.  
To locate IDSDM or vFlash, see the [System board jumpers and connectors](#) section.
- 2 Holding the pull tab, lift the IDSDM or vFlash module out of the system.

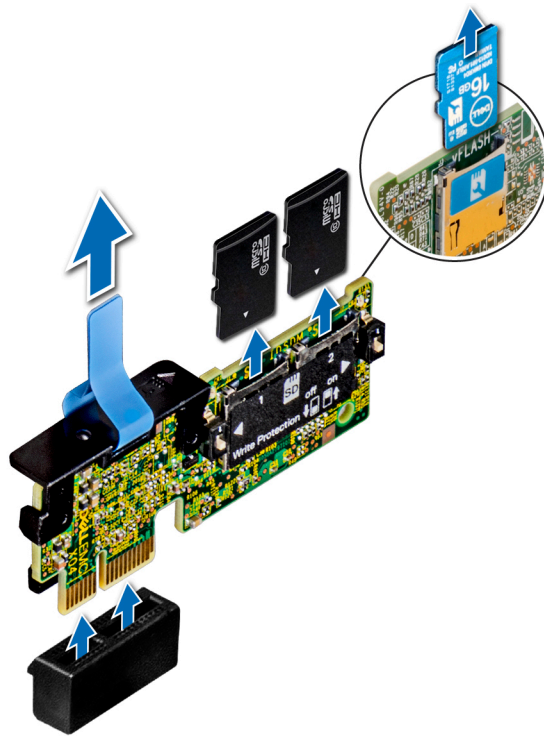

Figure 57. Removing the IDSDM or vFlash module

**NOTE:** To enable or disable write-protection, use the dip switches that are on the IDSDM or vFlash module.

## Next step

Install the IDSDM or vFlash module. For more information, see [Installing the IDSDM or vFlash module](#).

# Installing the IDSDM or vFlash module

## Prerequisite

Follow the safety guidelines listed in [Safety instructions](#).

## Steps

- 1 Locate the IDSDM or vFlash connector on the system board.  
To locate IDSDM or vFlash, see the [System board jumpers and connectors](#) section.
- 2 Align the IDSDM or vFlash module with the connector on the system board.
- 3 Push the IDSDM or vFlash module until it is firmly seated in the connector on the system board.

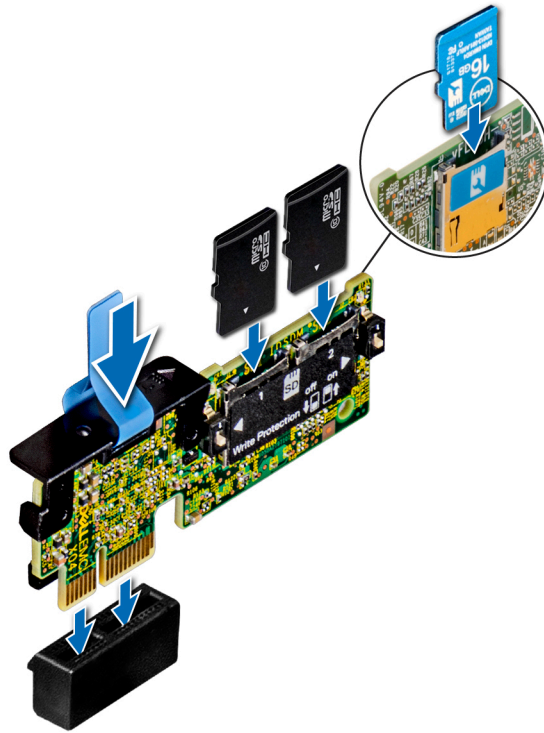

**Figure 58. Installing the IDSDM or vFlash module**

## Next steps

- 1 Install the MicroSD cards. For more information, see [Installing the MicroSD card](#).  
**NOTE:** Reinstall the MicroSD cards into the slots based on the labels you had marked on the cards during removal.
- 2 Follow the procedure listed in [After working inside your system](#).

# LOM riser card

The LOM riser card is a small, removable mezzanine card, which provides the flexibility of selecting different network connectivity options.

# Removing the LOM riser card

## Prerequisites

- 1 Follow the safety guidelines listed in [Safety instructions](#).
- 2 Follow the procedure listed in [Before working inside your system](#).
- 3 Remove the air shroud. For more information, see [Removing the air shroud](#).
- 4 If installed, remove the risers. For more information see, [Removing the expansion card risers](#).

## Steps

- 1 Using a Phillips #2 screwdriver, remove the screws that secure the LAN on Motherboard (LOM) riser card to the system board.
- 2 Push apart the two blue plastic clips securing the LOM riser card to release the riser.
- 3 Hold the LOM riser card by the edges on either side, and lift to remove it from the connector on the system board.
- 4 Slide the LOM riser card towards the front of the system until the Ethernet connectors or the SFP+ are clear of the slot in the back panel.

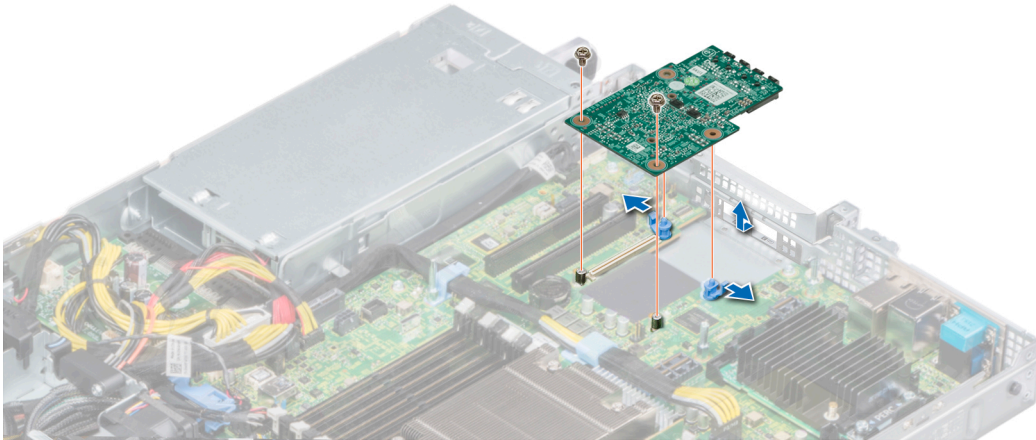

**Figure 59. Removing the LOM riser card**

- 5 Remove the LOM bracket.
  - a Using the Phillips #2 screwdriver, remove the screw that secures the bracket to the chassis.
  - b Slide the bracket out of the slot on the chassis.

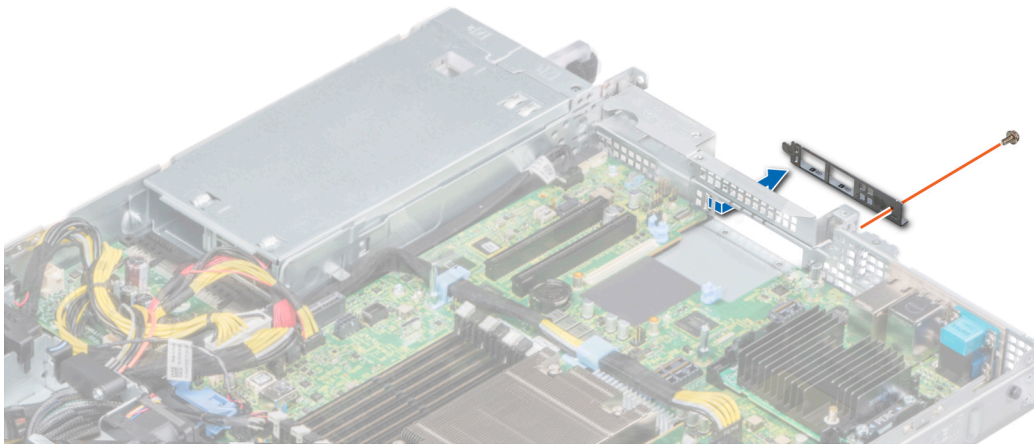

**Figure 60. Removing the LOM bracket**

- 6 If the LOM riser is not being replaced immediately, install the LOM filler bracket.
  - a Insert and slide the filler into the slot on the chassis.
  - b Using the Phillips #2 screwdriver, secure the filler bracket to the chassis with a screw.

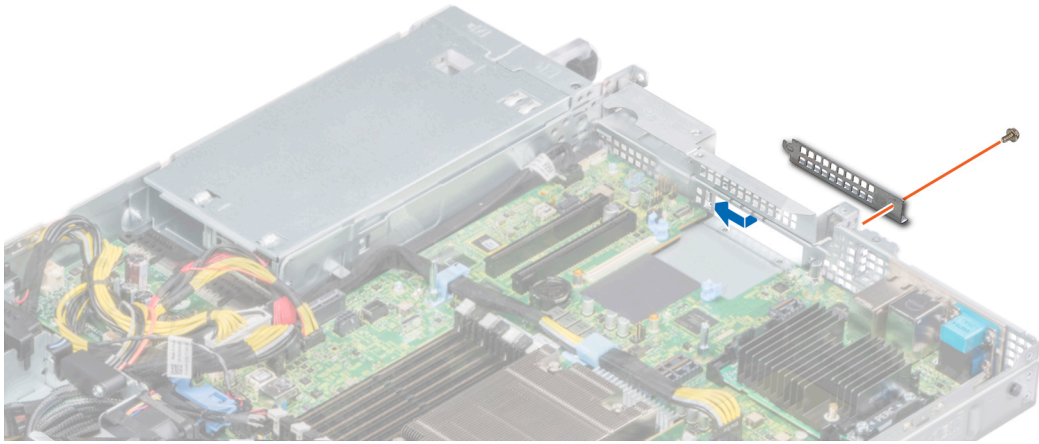

**Figure 61. Installing the LOM filler bracket**

**Next step**

Install the LOM riser card. For more information, see [Installing the LOM riser card](#).

## Installing the LOM riser card

**Prerequisites**

- 1 Follow the safety guidelines listed in [Safety instructions](#).
- 2 Follow the procedure listed in [Before working inside your system](#).
- 3 Remove the air shroud. For more information, see [Removing the air shroud](#).
- 4 If installed, remove the risers. For more information see, [Removing the expansion card risers](#).

**Steps**

- 1 Remove the LAN on Motherboard (LOM) filler bracket.
  - a Using the Phillips #2 screwdriver, remove the screw that secures the bracket to the chassis.
  - b Slide the bracket out of the slot on the chassis.

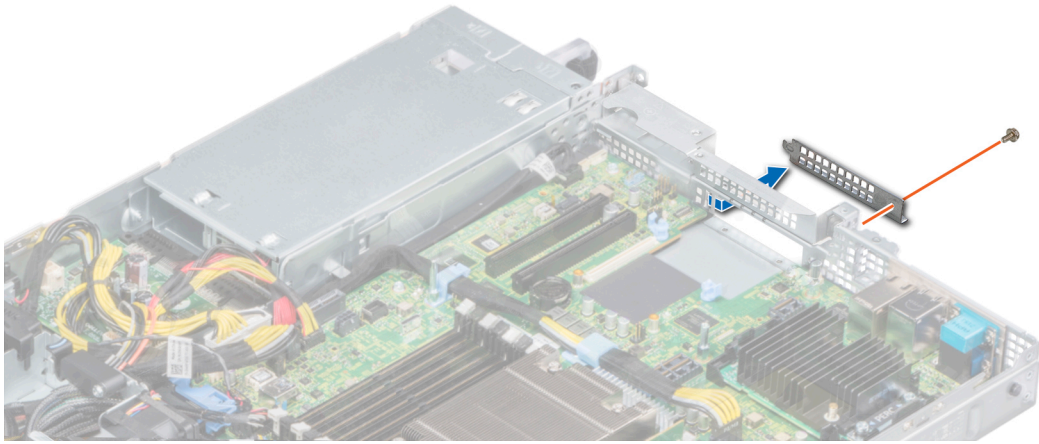

**Figure 62. Removing the LOM filler bracket**

- 2 Install the LOM bracket.
  - a Insert and slide the LOM bracket into the slot on the chassis.
  - b Using the Phillips #2 screwdriver, secure the bracket to the chassis with a screw

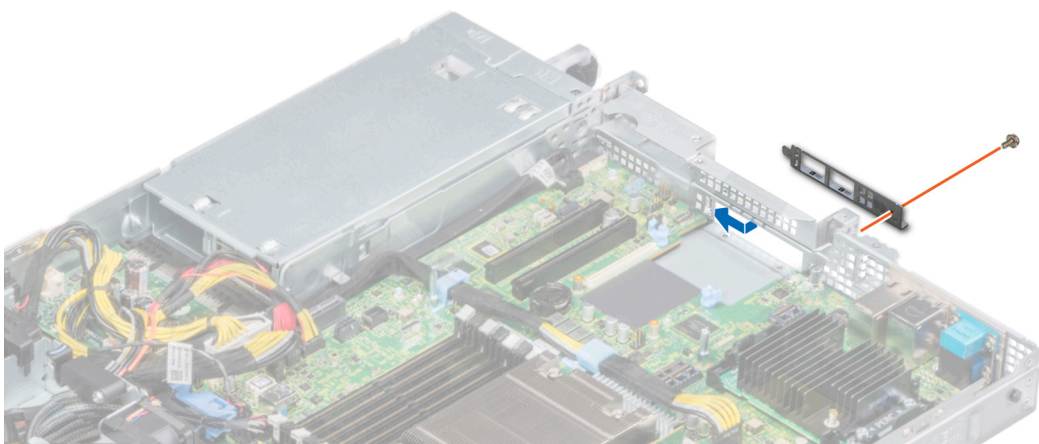

**Figure 63. Installing the LOM bracket**

- 3 Orient the LOM riser card to fit the Ethernet connectors or the SFP+ through the slot of the bracket.
- 4 Press the LOM riser card until the card is firmly seated on the system board connector and the two blue plastic clips, secure the LOM riser card in place.
- 5 Using a Phillips #2 screwdriver, secure the LOM riser card to the system board with screws.

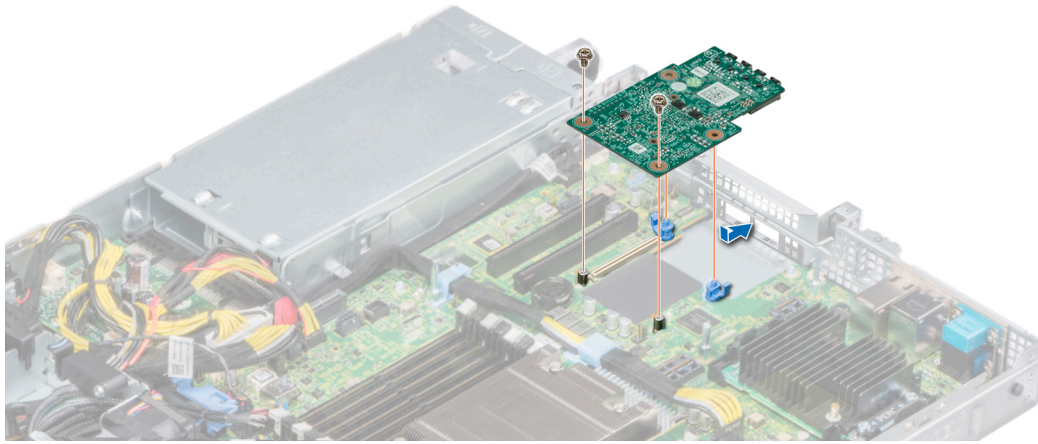

**Figure 64. Installing the LOM riser card**

### Next steps

- 1 If removed, install the risers. For more information, see [Installing the expansion card risers](#).
- 2 Install the air shroud. For more information, see [Installing the air shroud](#).
- 3 Follow the procedure listed in [After working inside your system](#).

## Mini PERC card

Your system includes a dedicated expansion card slot on the system board for the primary storage controller card. The mini PERC card provides the storage subsystem for internal drives of your system. The mini PERC card supports SAS and SATA drives and also enables you to set up the drives in RAID configurations as supported by the version of the mini PERC card.

## Removing the mini PERC card

### Prerequisites

- 1 Follow the safety guidelines listed in [Safety instructions](#).
- 2 Follow the procedure listed in [Before working inside your system](#).
- 3 Remove the air shroud. For more information, see [Removing the air shroud](#).
- 4 If installed, remove the right riser. For more information, see [Removing the expansion card risers](#).

### Steps

- 1 Using a Phillips #2 screwdriver, loosen the captive screws that secure the cable to the mini PERC card.
- 2 Holding the tab, lift the cable to disconnect it from the mini PERC card.
- 3 Slide out the mini PERC card to disengage from the card holder on the system board.
- 4 Lift the mini PERC card out of the system.

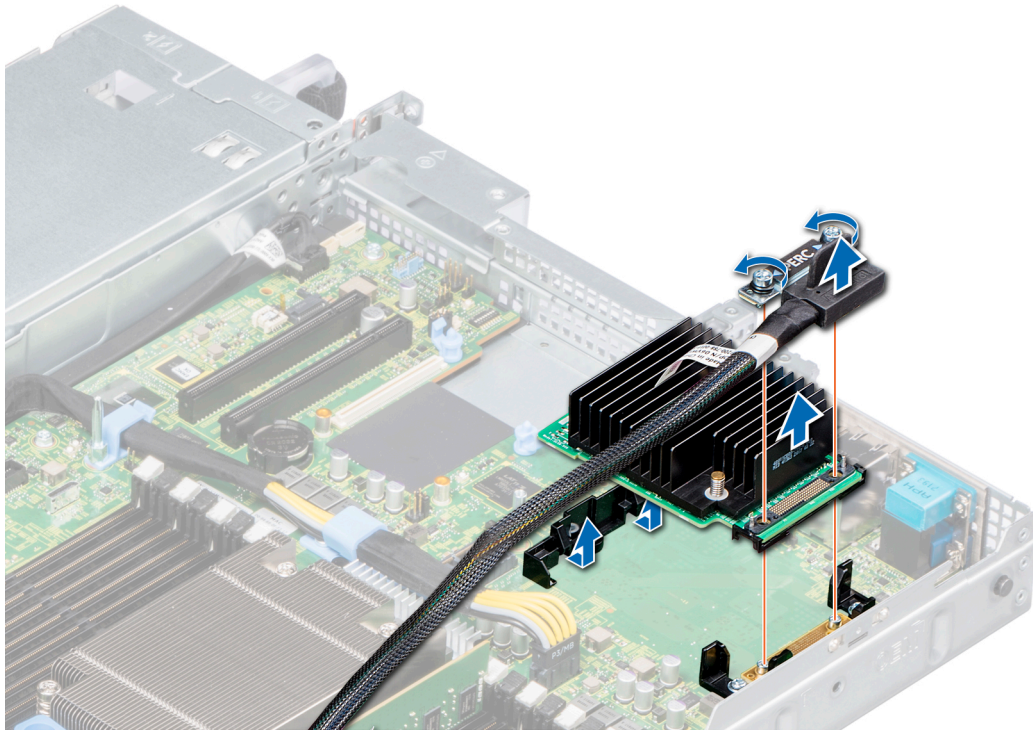

**Figure 65. Removing the mini PERC card**

**Next step**

Install the mini PERC card. For more information, see [Installing the mini PERC card](#).

## Installing the mini PERC card

**Prerequisite**

Follow the safety guidelines listed in [Safety instructions](#).

**Steps**

- 1 Angle the mini PERC card to engage with the mini PERC card holder on the system board.
- 2 Lower the mini PERC card into place until the mini PERC card is firmly seated on the mini PERC card holder.
- 3 Align the screws on the cable with the screw holes on the mini PERC card.
- 4 Using Phillips #2 screwdriver, tighten the captive screws to secure the cable to the mini PERC card.

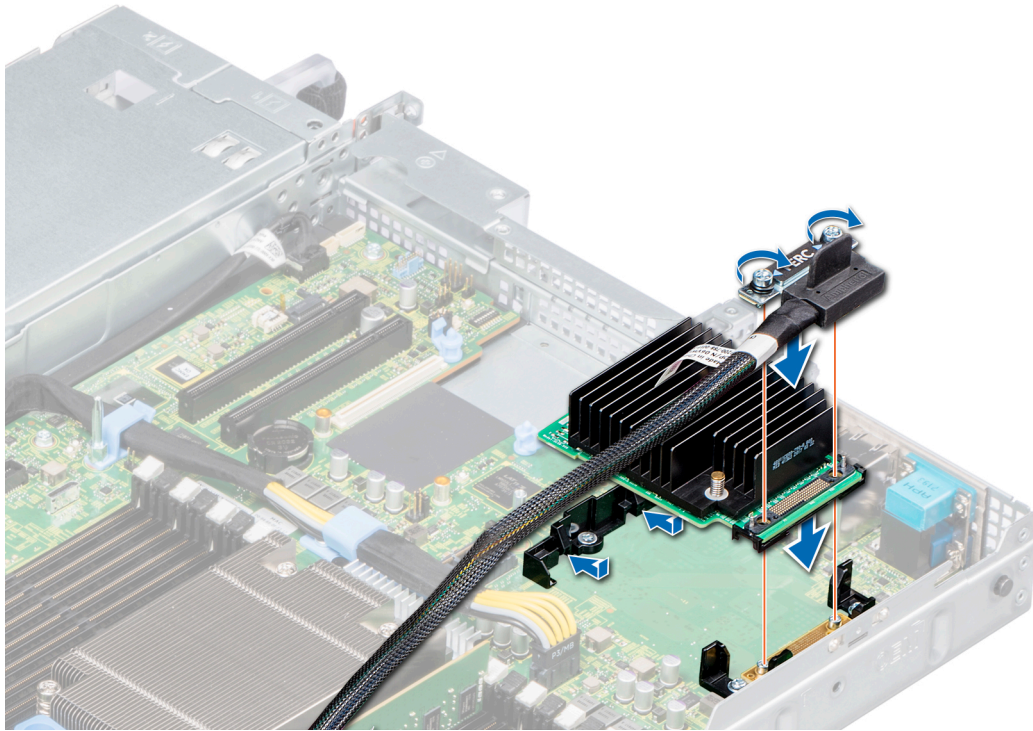

**Figure 66. Installing the mini PERC card**

**Next steps**

- 1 If removed install the risers. For more information, see [Installing the expansion card risers](#).
- 2 Install the air shroud. For more information, see [Installing the air shroud](#).
- 3 Follow the procedure listed in [After working inside your system](#).

## Drive backplane

Depending on your system configuration, the drive backplanes supported in PowerEdge R6415 are listed here:

**Table 45. Supported backplane options**

System	Supported hard drives options
PowerEdge R6415	3.5 inch (x4) SAS, SATA backplane 2.5 inch (x8) SAS or SATA backplane 2.5 inch (x10) SAS, SATA or NVMe backplane

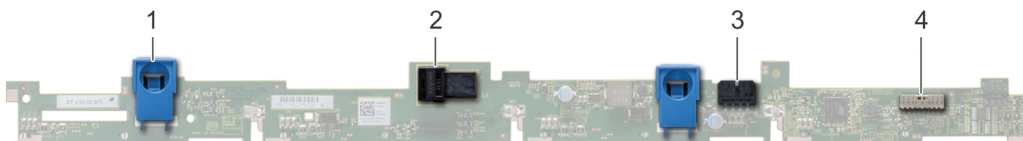

**Figure 67. 4 x 3.5 drive backplane**

- 1 release tab
- 2 SAS\_A connector on the backplane

3 backplane power cable

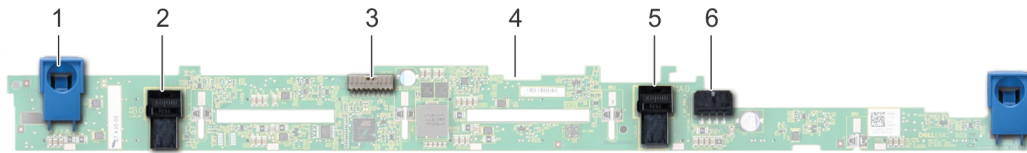

Figure 68. 8 x 2.5 drive backplane

1 release tab

2 SATA\_A cable connector

3 backplane signal cable

4 backplane

5 SATA\_B cable connector

6 backplane power cable



Figure 69. 10 x 2.5 SAS, SATA or NVMe drive backplane

1 B0 NVMe cable connector

2 I2C cable connector

3 A0 NVMe cable connector

4 SAS/SATA cable connector

5 B1 NVMe cable connector

6 A1 NVMe cable connector

7 SAS/SATA cable connector

8 A2 NVMe cable connector

9 backplane power connector

## Removing the backplane

### Prerequisites

**⚠ CAUTION:** To prevent damage to the drives and backplane, remove the drives from the system before removing the backplane.

**⚠ CAUTION:** Note the number of each drive and temporarily label them before you remove the drive so that you can reinstall them in the same location.

**📌 NOTE:** The procedure to remove the backplane is similar for all backplane configurations.

- 1 Follow the safety guidelines listed in [Safety instructions](#).
- 2 Follow the procedure listed in [Before working inside your system](#).
- 3 If applicable, remove the backplane cover. For more information, see [Removing the backplane cover](#).
- 4 Remove all the drives. For more information, see [Removing a drive carrier](#).
- 5 Disconnect the VGA cable from the system board.
- 6 If installed, disconnect the optical drive signal and power cables from the drive.

### Steps

- 1 Lift the cable guiding latch up.
- 2 Press the blue release tabs and lift the backplane to disengage the backplane from the hooks on the system.
  - a Remove the backplane power cable, the I2C cable and the SAS, SATA or NVMe cables



**Figure 70. Removing the backplane**

**Next step**

Install the backplane. For more information, see [Installing the drive backplane](#).

## Installing the drive backplane

**Prerequisite**

Follow the safety guidelines listed in [Safety instructions](#).

**NOTE:** The procedure to install the backplane is similar for all backplane configurations.

**Steps**

- 1 Connect the SAS, SATA, or NVME cable to the backplane.
- 2 Use the hooks on the system chassis as guides to align the slots on the backplane with the guides on the system.
- 3 Insert the backplane into the guides and lower the backplane until the blue release tabs snap into place securing the backplane.

**Figure 71. Installing the backplane**



### Next steps

- 1 Reconnect the VGA cable to the system board.
- 2 If disconnected, reconnect the optical drive power and signal cables to the drive.
- 3 Reconnect all the disconnected cables to the backplane. For more information, see [Cable routing](#)
- 4 Reinstall the all the removed drives, into their original slots. For more information, see [Installing a drive carrier](#).
- 5 If applicable, install the backplane cover. For more information, see [Installing the backplane cover](#).
- 6 Follow the procedure listed in [After working inside your system](#).

# Cable routing

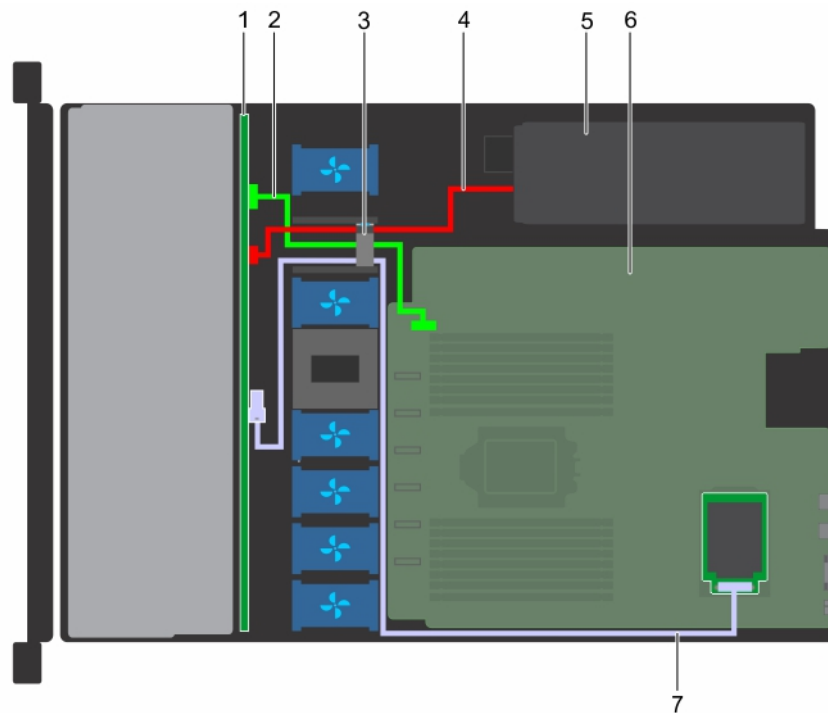

**Figure 72. Cable routing - 4 x 3.5 inch drive backplane to the mini-PERC card**

- |   |                              |   |                       |
|---|------------------------------|---|-----------------------|
| 1 | 4 x 3.5 inch drive backplane | 2 | I2C cable             |
| 3 | cable guiding latch          | 4 | backplane power cable |
| 5 | power supplies               | 6 | system board          |
| 7 | mini-PERC card               |   |                       |

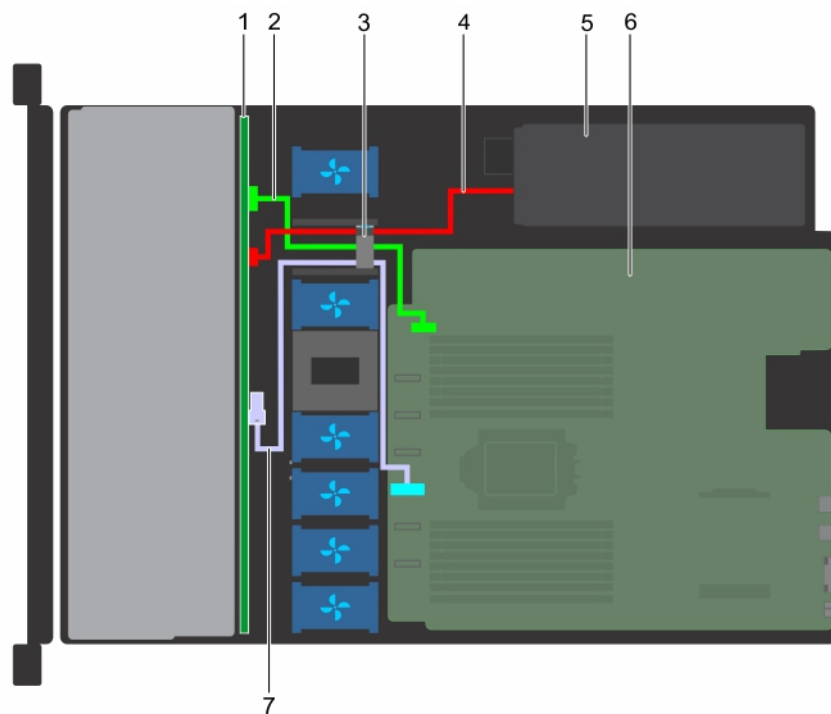

**Figure 73. Cable routing - 4 x 3.5 inch drive backplane to the onboard controller**

- |   |                              |   |                       |
|---|------------------------------|---|-----------------------|
| 1 | 4 x 3.5 inch drive backplane | 2 | I2C cable             |
| 3 | cable guiding latch          | 4 | backplane power cable |
| 5 | power supplies               | 6 | system board          |
| 7 | onboard SATA connector       |   |                       |

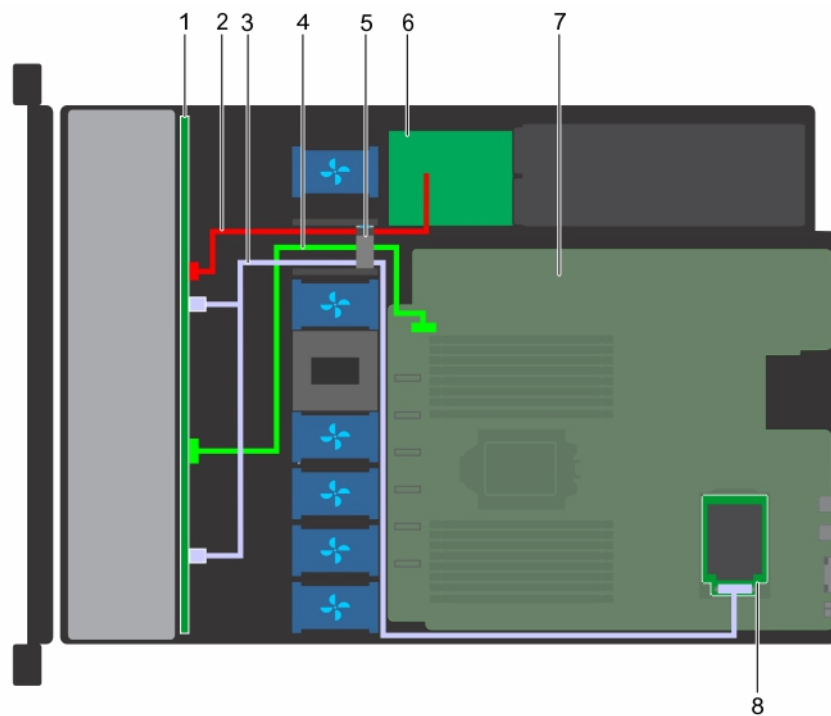

**Figure 74. Cable routing - 8 x 2.5 inch drive backplane to the mini-PERC card**

- |   |                              |   |                        |
|---|------------------------------|---|------------------------|
| 1 | 8 x 2.5 inch drive backplane | 2 | backplane power cable  |
| 3 | SAS cables                   | 4 | I2C cable              |
| 5 | cable guiding latch          | 6 | power interposer board |
| 7 | system board                 | 8 | mini-PERC card         |

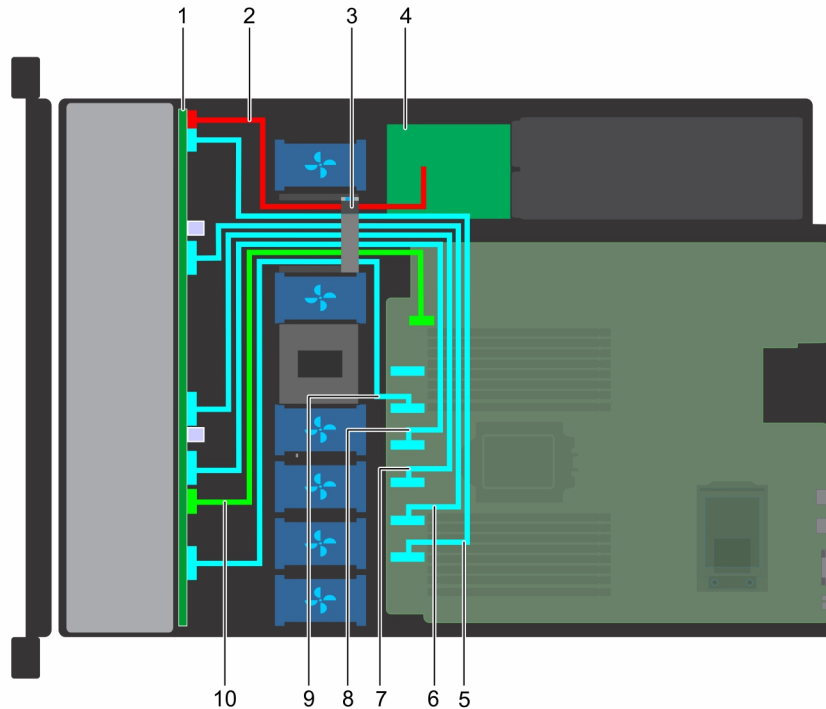

**Figure 75. Cable routing - 10 x 2.5 inch drive backplane to the onboard controller (NVMe)**

- |   |                               |    |                        |
|---|-------------------------------|----|------------------------|
| 1 | 10 x 2.5 inch drive backplane | 2  | backplane power cable  |
| 3 | cable guiding latch           | 4  | power interposer board |
| 5 | PCIe B cable                  | 6  | SATA_B/PCIE C cable    |
| 7 | PCIe D cable                  | 8  | PCIe E cable           |
| 9 | PCIe F cable                  | 10 | I2C cable              |

## System battery

The system battery is used for low-level system functions such as powering the real-time and date settings of the system.

## Replacing the system battery

### Prerequisites

**⚠ WARNING:** There is a danger of a new battery exploding if it is incorrectly installed. Replace the battery only with the same or equivalent type recommended by the manufacturer. For more information, see the safety information that shipped with your system.

- 1 Follow the safety guidelines listed in [Safety instructions](#).
- 2 Follow the procedure listed in [Before working inside your system](#).
- 3 If applicable, disconnect the power or data cables from expansion card(s).
- 4 If installed, remove the risers. For more information, see [Removing the expansion card risers](#).

### Steps

- 1 Locate the battery socket. For more information, see the [System board jumpers and connectors](#) section.

**CAUTION:** To avoid damage to the battery connector, you must firmly support the connector while installing or removing a battery.

- 2 Use a plastic scribe to pry out the system battery.



**Figure 76. Removing the system battery**

- 3 To install a new system battery, hold the battery with the positive side facing up and slide it under the securing tabs.
- 4 Press the battery into the connector until it snaps into place.

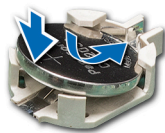

**Figure 77. Installing the system battery**

#### Next steps

- 1 If removed, install the risers. For more information, see [Installing the expansion card risers](#).
- 2 Reconnect the cables to the expansion card(s).
- 3 Follow the procedure listed in [After working inside your system](#).
- 4 While booting, press F2 to enter the System Setup.
- 5 Enter the correct time and date in the System Setup **Time** and **Date** fields.
- 6 Exit the System Setup.

## Optional internal USB memory key

An optional USB memory key installed inside your system can be used as a boot device, security key, or mass storage device. To boot from the USB memory key, configure the USB memory key with a boot image and then specify the USB memory key in the boot sequence in System Setup.

An optional USB memory key can be installed in the internal USB 3.0 port.

**NOTE:** To locate the internal USB port on the system board, see the [System board jumpers and connectors](#) section.

# Replacing the internal USB memory key

## Prerequisites

**CAUTION:** To avoid interference with other components in the server, the maximum permissible dimensions of the USB memory key are 15.9 mm wide x 57.15 mm long x 7.9 mm high.

- 1 Follow the safety guidelines listed in [Safety instructions](#).
- 2 Follow the procedure listed in [Before working inside your system](#).
- 3 If applicable, disconnect the power or data cables from expansion card(s).
- 4 If installed, remove the risers. For more information, see [Removing the expansion card risers](#).

## Steps

- 1 Locate the USB port or USB memory key on the system board.  
To locate the internal USB port on the system board, see the [System board jumpers and connectors](#) section.
- 2 If installed, remove the USB memory key from the USB port.
- 3 Insert the replacement USB memory key into the USB port.

## Next steps

- 1 If removed, install the risers. For more information, see [Installing the expansion card risers](#).
- 2 Reconnect the cables to the expansion card(s).
- 3 Follow the procedure listed in [After working inside your system](#).
- 4 While booting, press F2 to enter **System Setup** and verify that the system detects the USB memory key.

# Optical drive (optional)

Optical drives retrieve and store data on optical discs such as CD and DVD. Optical drives can be categorized into two basic types: optical disc readers and optical disc writers.

# Removing the optical drive

## Prerequisites

- 1 Follow the safety guidelines listed in [Safety instructions](#).
- 2 Follow the procedure listed in [Before working inside your system](#).
- 3 Disconnect the power and data cables from the connectors on the optical drive.

**NOTE:** Ensure that you note the routing of the power and data cable on the side of the system as you remove them from the system board and drive. Route these cables properly when you replace them to prevent them from being pinched or crimped.

## Steps

- 1 Press the release tab to release the optical drive.
- 2 Slide the optical drive out of the system until it is free of the optical drive slot.

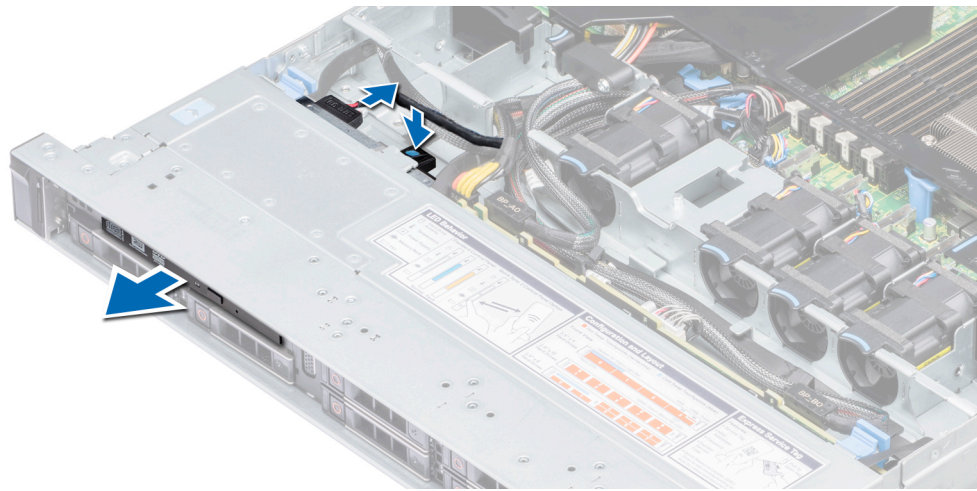

**Figure 78. Removing the optical drive**

- 3 If you are not installing a new optical drive, install the optical drive blank. The procedure to install the optical drive blank is the same as installing the optical drive.

**Next step**

Install an optical drive. For more information, see [Installing an optical drive](#).

## Installing an optical drive

**Prerequisite**

Follow the safety guidelines listed in [Safety instructions](#).

**Steps**

- 1 If installed, remove the optical drive blank. The procedure to remove an optical blank is similar to removing an optical drive.
- 2 Align the optical drive with the optical drive slot on the front of the system.
- 3 Slide in the optical drive until the release tab snaps into place.

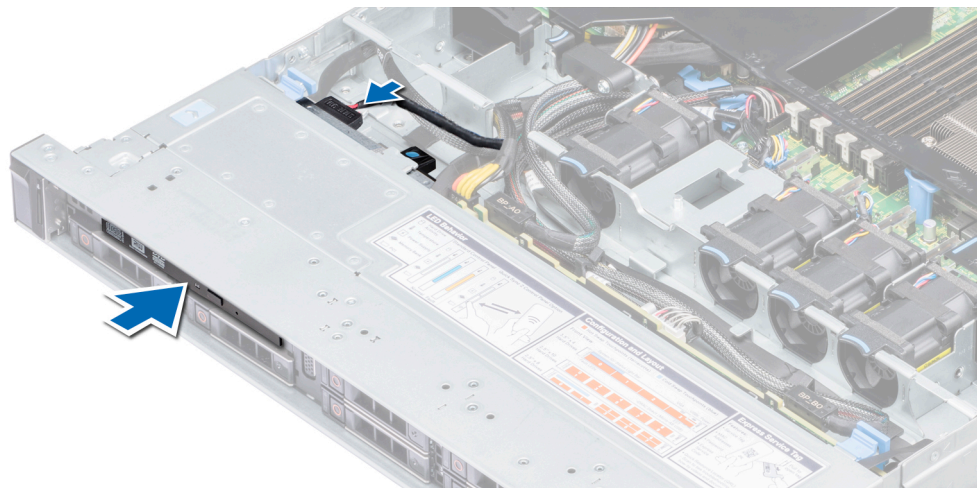

**Figure 79. Installing an optical drive**

## Next steps

1 Connect the power and data cables to the connector on the optical drive.

**NOTE:** Route the cable properly on the side of the system to prevent it from being pinched or crimped.

2 Follow the procedure listed in [After working inside your system](#).

# Power supply units

The power supply unit (PSU) is an internal hardware component which supplies power to the components in the system.

Your system supports one of the following:

- Two 550 W AC PSUs (redundant)
- One 450 W AC PSU (cabled)

**NOTE:** For more information, see the [Technical specifications section](#).

**CAUTION:** If two PSUs are installed, both the PSUs must have the same type of label. For example, Extended Power Performance (EPP) label. Mixing PSUs from previous generations of PowerEdge servers is not supported, even if the PSUs have the same power rating. Mixing PSUs will result in mismatch condition or failure to turn the system on.

**NOTE:** When two identical PSUs are installed, power supply redundancy (1+1 – with redundancy or 2+0 – without redundancy) is configured in system BIOS. In redundant mode, power is supplied to the system equally from both PSUs when Hot Spare is disabled. When Hot Spare is enabled, one of the PSUs is put into the sleep mode when system utilization is low in order to maximize efficiency.

**NOTE:** If two PSUs are used, they must be of the same maximum output power.

## Hot spare feature

Your system supports the hot spare feature that significantly reduces the power overhead associated with power supply unit (PSU) redundancy.

When the hot spare feature is enabled, one of the redundant PSUs is switched to the sleep state. The active PSU supports 100 percent of the load, thus operating at higher efficiency. The PSU in the sleep state monitors output voltage of the active PSU. If the output voltage of the active PSU drops, the PSU in the sleep state returns to an active output state.

If having both PSUs active is more efficient than having one PSU in the sleep state, the active PSU can also activate the sleeping PSU.

The default PSU settings are as follows:

- If the load on the active PSU is more than 50 percent, then the redundant PSU is switched to the active state.
- If the load on the active PSU falls below 20 percent, then the redundant PSU is switched to the sleep state.

You can configure the hot spare feature by using the iDRAC settings. For more information about iDRAC settings, see the *Integrated Dell Remote Access Controller User's Guide* available at [Dell.com/idracmanuals](http://Dell.com/idracmanuals).

## Removing a power supply unit blank

### Prerequisite

Follow the safety guidelines listed in [Safety instructions](#).

### Step

If you are installing a second power supply unit (PSU), remove the PSU blank in the bay by pulling the blank outward.

**CAUTION:** To ensure proper system cooling, the PSU blank must be installed in the second PSU bay in a non-redundant configuration. Remove the PSU blank only if you are installing a second PSU.

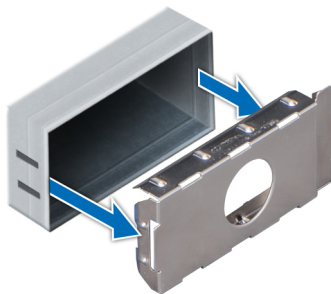

Figure 80. Removing a power supply unit blank

#### Next step

Install a PSU, for more information, see [Installing a hot swappable power supply unit](#) or install a PSU blank, for more information, see [PSU blank](#).

## Installing a power supply unit blank

#### Prerequisites

- 1 Follow the safety guidelines listed in [Safety instructions](#).
- 2 Install the power supply unit (PSU) blank only in the second PSU bay.

#### Step

Align the PSU blank with the PSU slot and push it into the PSU slot until it clicks into place.

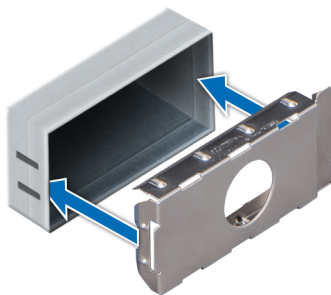

Figure 81. Installing a power supply unit blank

## Removing a hot swappable power supply unit

#### Prerequisites

**CAUTION:** The system needs one power supply unit (PSU) for normal operation. On power-redundant systems, remove and replace only one PSU at a time in a system that is powered on.

- 1 Follow the safety guidelines listed in [Safety instructions](#).
- 2 Disconnect the power cable from the power source and from the PSU you intend to remove, and then remove the cable from the strap on the PSU handle.

- Unlatch and lift the optional cable management arm if it interferes with the PSU removal.  
For information about the cable management arm, see the system's rack documentation at [Dell.com/poweredge manuals](https://Dell.com/poweredge manuals).

**Step**

Press the orange release latch and pull the PSU out of the system using the PSU handle.

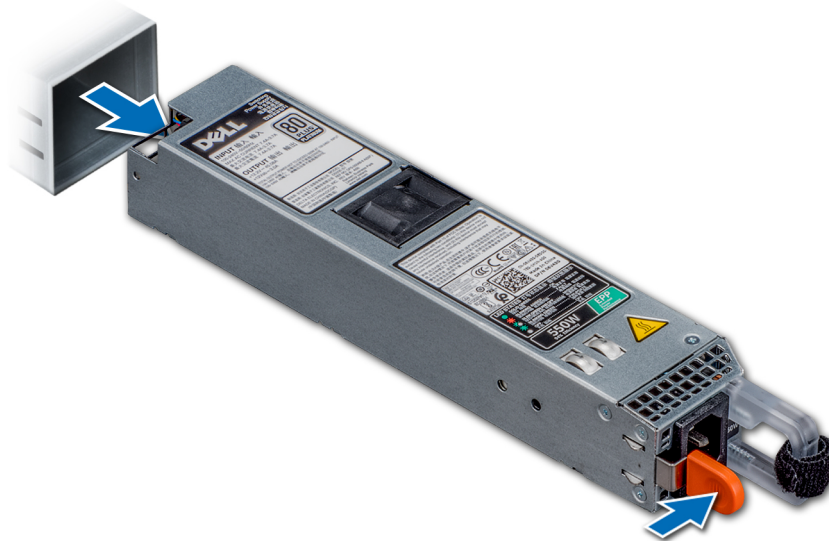

**Figure 82. Removing a power supply unit**

**Next step**

Install a PSU, for more information, see [Installing a hot swappable power supply unit](#) or install a PSU blank, for more information, see [PSU blank](#).

## Installing a hot swappable power supply unit

**Prerequisites**

- Follow the safety guidelines listed in [Safety instructions](#).
- For systems that support redundant PSU, ensure that both the PSUs are of the same type and have the same maximum output power.

**NOTE:** The maximum output power (shown in watts) is listed on the PSU label.

**Step**

Slide the PSU into the system until the PSU is fully seated and the release latch snaps into place.



**Figure 83. Installing a hot swappable PSU**

#### Next steps

- 1 If you have unlatched the cable management arm, re-latch it. For information about the cable management arm, see the system's rack documentation at [Dell.com/poweredgemanuals](https://www.dell.com/poweredge/manuals).
- 2 Connect the power cable to the PSU, and plug the cable into a power outlet.

**CAUTION:** When connecting the power cable to the PSU, secure the cable to the PSU with the strap.

**NOTE:** When installing, hot swapping, or hot adding a new PSU, wait for 15 seconds for the system to recognize the PSU and determine its status. The PSU redundancy may not occur until discovery is complete. Wait until the new PSU is discovered and enabled before you remove the other PSU. The PSU status indicator turns green to signify that the PSU is functioning properly.

## Removing a cabled power supply unit

#### Prerequisites

- 1 Follow the safety guidelines listed in [Safety instructions](#).
- 2 Follow the procedure listed in [Before working inside your system](#).
- 3 Remove the air shroud. For more information, see [Removing the air shroud](#).
- 4 Disconnect all the cables connected to the system board and backplane.

#### Steps

- 1 Using Phillips #2 screwdriver, remove the screw securing the PSU to the system.
- 2 Slide the PSU towards the front of the system and lift it out of the PSU cage.

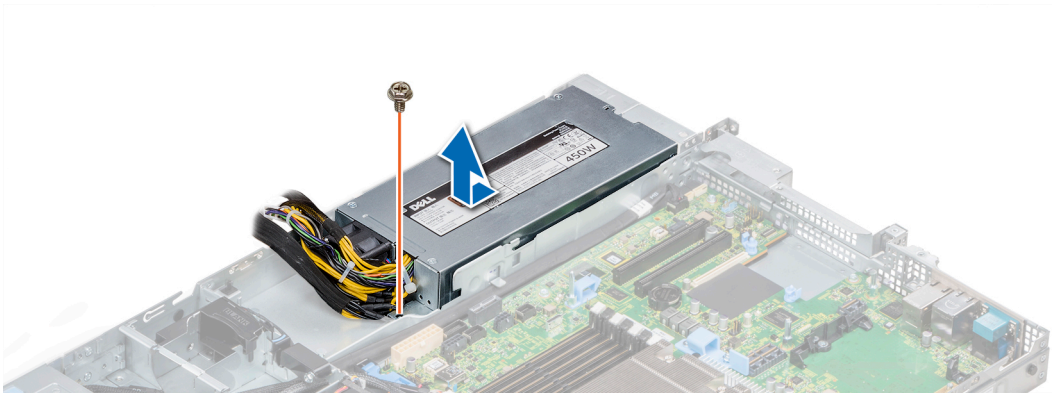

**Figure 84. Removing a cabled PSU**

#### Next step

- 1 Installing a installing a cabled PSU. For more information see, [Installing a cabled power supply unit](#).

## Installing a cabled power supply unit

#### Prerequisite

- 1 Follow the safety guidelines listed in [Safety instructions](#).

#### Steps

- 1 Unpack the new power supply unit (PSU).
- 2 Slide the new PSU into the PSU cage until the PSU is fully seated.
- 3 Using Phillips #2 screwdriver, tighten the screw to secure the PSU to the system.

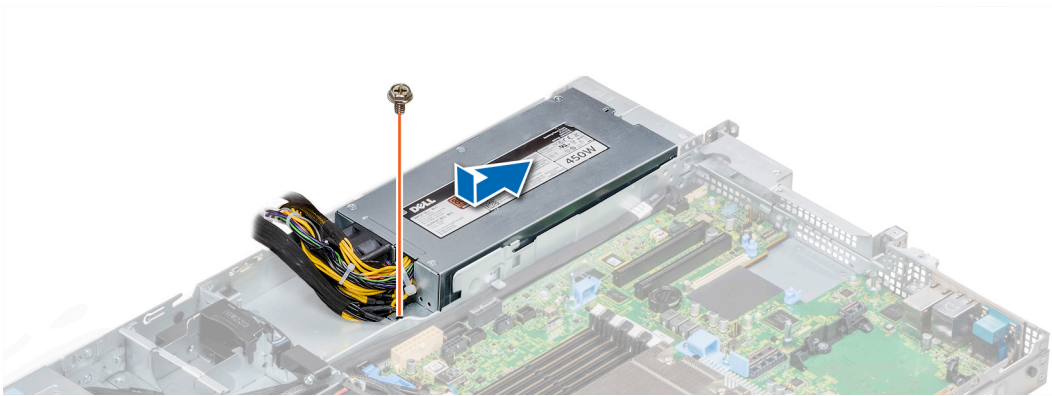

**Figure 85. Installing a cabled PSU**

#### Next steps

- 1 Connect all the cables to the system board and backplane.
- 2 Install the air shroud. For more information, see [Installing the air shroud](#).
- 3 Follow the procedure listed in [After working inside your system](#).

# Power interposer board

The power interposer board (PIB) is a board that connects the hot swappable power supply units (PSUs) to the system board. The PIB is only supported in systems with redundant PSUs.

## Removing the power interposer board

### Prerequisites

- 1 Follow the safety guidelines listed in [Safety instructions](#).
- 2 Follow the procedure listed in [Before working inside your system](#).
- 3 Remove the air shroud. For more information, see [Removing the air shroud](#).
- 4 Disconnect all the cables connected to the system board and backplane.
- 5 Remove the power supply units (PSUs). For more information, see [Removing a hot swappable power supply unit](#).

**CAUTION:** To prevent damage to the power interposer board (PIB), you must remove the PSUs from the system before removing the power interposer board.

### Steps

- 1 Using Phillips #2 screwdriver, remove the two screws securing the PIB to the system.
- 2 Lift the PIB away from the system.

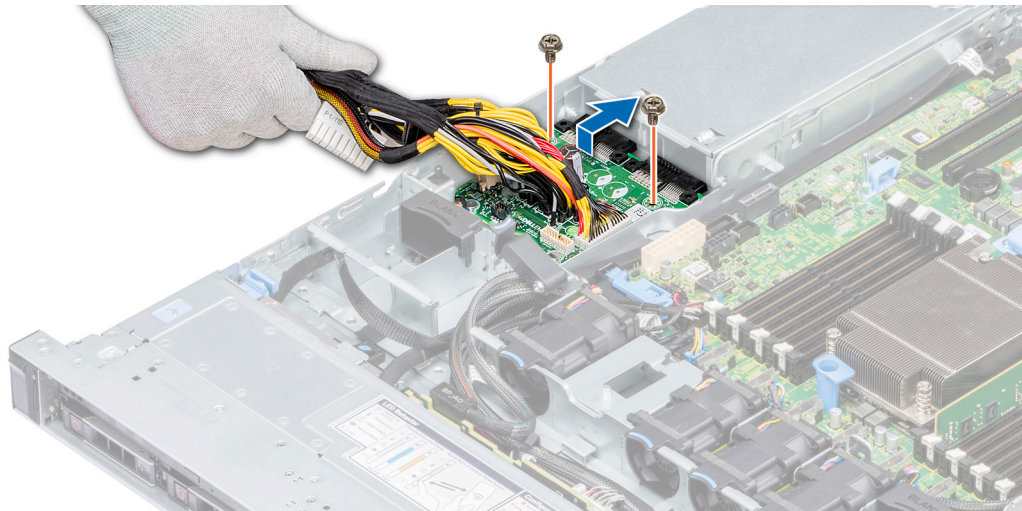

Figure 86. Removing the PIB

### Next step

- 1 Install the power interposer board. For more information, see [Installing the power interposer board](#).

## Installing the power interposer board

### Prerequisite

Follow the safety guidelines listed in [Safety instructions](#).

## Steps

- 1 Align the slots on the PIB with the standoffs on the system and slide the PIB into place.
- 2 Using Phillips #2 screwdriver, tighten the two screws to secure the PIB to the system.
- 3 Route the cables and connect them to the system board and backplane.

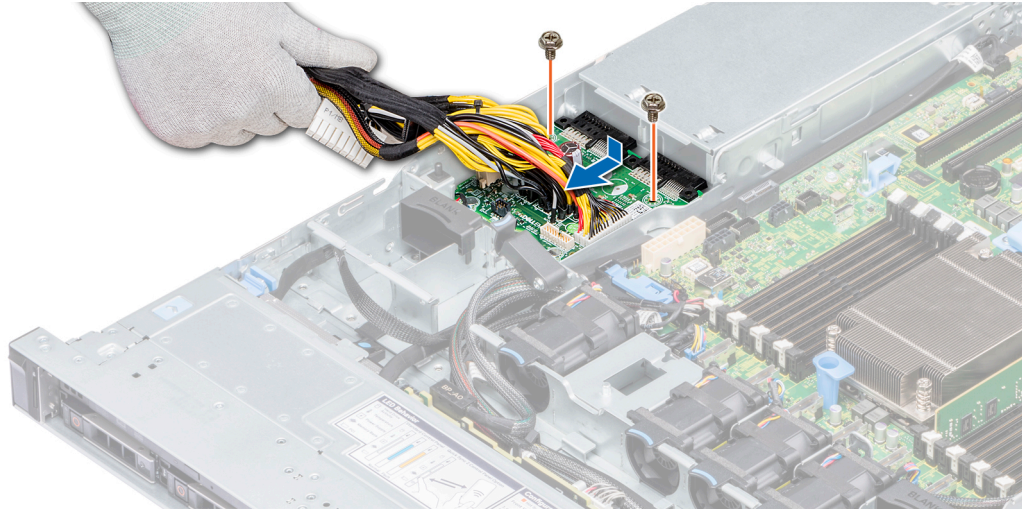

Figure 87. Installing the power interposer board

## Next steps

- 1 Install the PSUs. For more information, see [Installing a hot swappable power supply unit](#).
- 2 Install the air shroud. For more information, see [Installing the air shroud](#).
- 3 Follow the procedure listed in [After working inside your system](#).

# Control panel

A control panel allows you to manually control the inputs to the server.

Your system supports:

- Left control panel: Contains status LEDs, system ID button, and iDRAC Quick Sync 2 (optional).
- Right control panel: Contains power button, USB 2.0 port, micro USB for iDRAC Direct, and status LED for iDRAC Direct.

# Removing the left control panel

## Prerequisites

- 1 Follow the safety guidelines listed in [Safety instructions](#).
- 2 Follow the procedure listed in [Before working inside your system](#).
- 3 If applicable, remove the backplane cover. For more information, see [Removing the backplane cover](#)
- 4 Remove the air shroud. For more information, see [Removing the air shroud](#).

**NOTE:** Ensure that you note the routing of the cables as you remove them from the system board. You must route the cables properly when you replace them to prevent the cables from being pinched or crimped.

- 5 Lift the cable guiding latch.

## Steps

- 1 Disconnect the control panel cable from the system board connector.
- 2 Using a Phillips #1 screwdriver, remove the screws that secure the cable cover to the system.
- 3 Using a Phillips #1 screwdriver, remove the screws that secure the left control panel assembly to the system.
- 4 Holding the sides of the left control panel assembly, pull it away from the system.

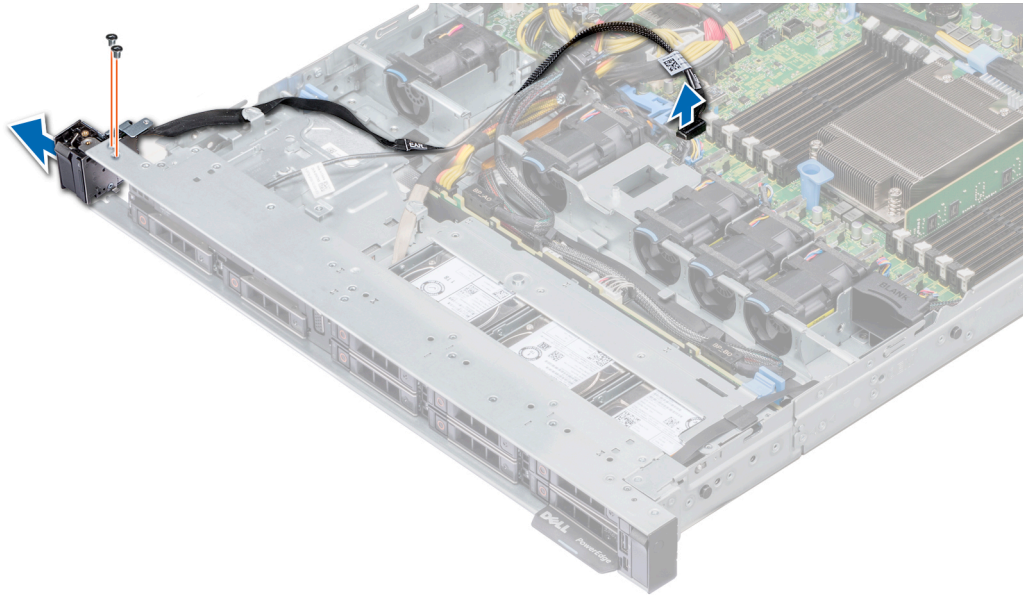

**Figure 88. Removing the left control panel**

## Next step

Install the left control panel. For more information, see [Installing the left control panel](#).

# Installing the left control panel

## Prerequisite

Follow the safety guidelines listed in [Safety instructions](#).

## Steps

- 1 Route the control panel cable through the side of the system.
- 2 Align the guides on the left control panel with the slots on the system and firmly slide the panel until it is firmly seated in place.
- 3 Using Phillips #1 screwdriver, tighten the screws to secure the left control panel assembly to the system.
- 4 Using Phillips #1 screwdriver, tighten the screws to secure the cable cover to the system.
- 5 Connect the control panel cable to the system board connector.

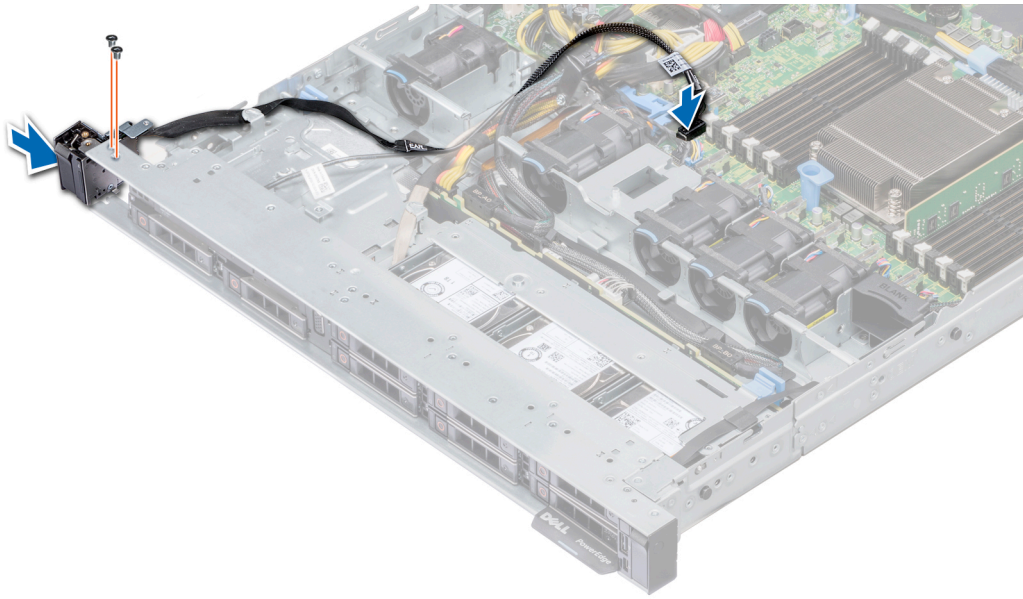

**Figure 89. Installing the left control panel**

#### Next steps

- 1 Install the air shroud. For more information, see [Installing the air shroud](#).
- 2 If applicable, install the backplane cover. For more information, see [Installing the backplane cover](#).
- 3 Close and secure the cable guiding latch.
- 4 Follow the procedure listed in [After working inside your system](#).

## Removing the right control panel

#### Prerequisites

**NOTE:** Ensure that you note the routing of the cables as you remove them from the system board. You must route the cables properly when you replace them to prevent the cables from being pinched or crimped.

- 1 Follow the safety guidelines listed in [Safety instructions](#).
- 2 Follow the procedure listed in [Before working inside your system](#).
- 3 If applicable, remove the backplane cover. For more information, see [Removing the backplane cover](#)
- 4 Remove the air shroud. For more information, see [Removing the air shroud](#).
- 5 Lift the cable guiding latch.

#### Steps

- 1 Using the Phillips #1 screwdriver, remove the screws that secure the cable cover and lift the cover away from the system.

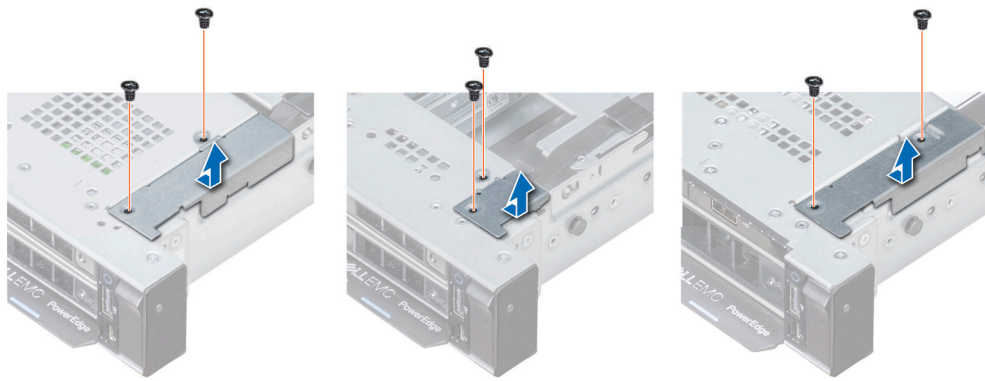
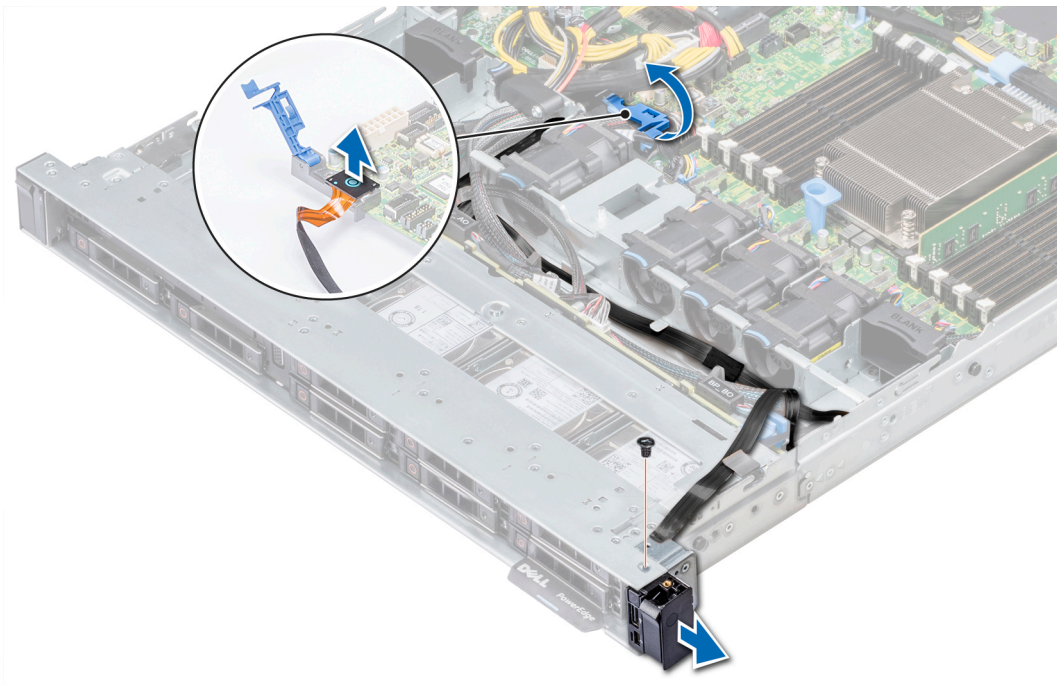

**Figure 90. Removing the cable cover**

- 2 Lift the cable latch and disconnect the right control panel cable from the system board.
- 3 Using the Phillips #1 screwdriver, remove the screws that secure the right control panel assembly to the system.

① **NOTE:** Note the cable guides and cable routing paths prior to removing the cables.

- 4 Holding the sides for the control panel, remove the panel away from the system.



**Figure 91. Removing the right control panel**

#### Next step

Install the right control panel. For more information, see [Installing the right control panel](#).

## Installing the right control panel

#### Prerequisite

Follow the safety guidelines listed in [Safety instructions](#).

## Steps

- 1 Route the control panel cable through the side wall of the system.
- 2 Align the guides on the right control panel with the slots on the system and firmly slide the panel until it is firmly seated in place.
- 3 Using a Phillips #1 screwdriver, replace the screws to secure the right control panel assembly to the system.

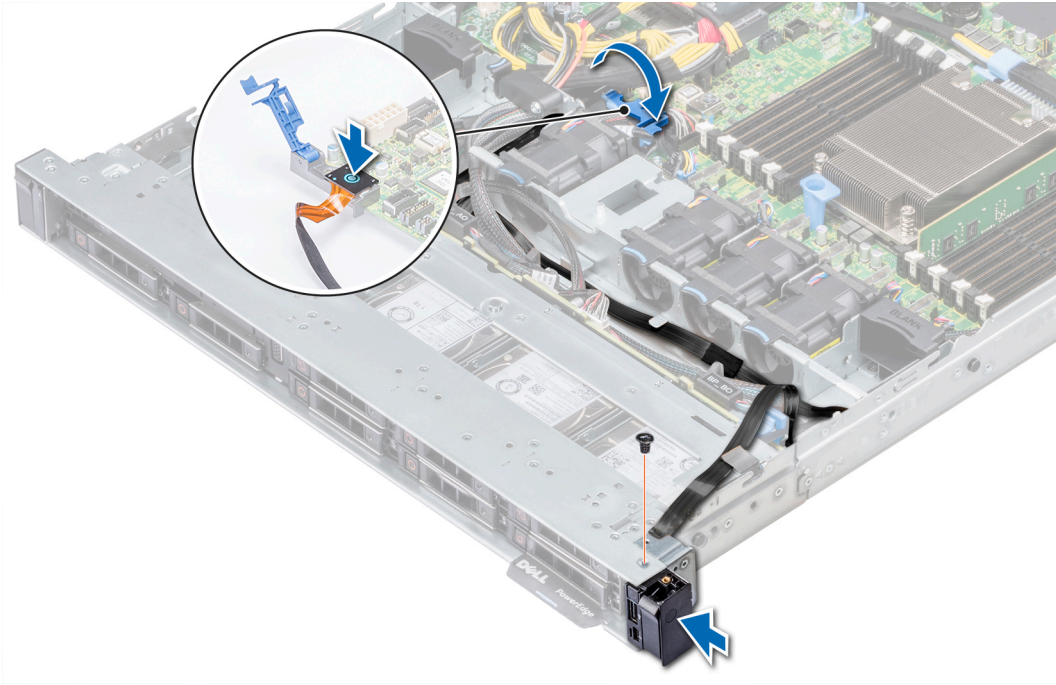

**Figure 92. Installing the right control panel**

- 4 Connect the control panel cable to the system board and secure it using cable latch.
- 5 Install the cable cover and secure it in place with screws, using a Phillips #1 screwdriver.



**Figure 93. Installing the cable cover**

## Next steps

- 1 Install the air shroud. For more information, see [Installing the air shroud](#).
- 2 If applicable, install the backplane cover. For more information, see [Installing the backplane cover](#).
- 3 Close and secure the cable guiding latch.
- 4 Follow the procedure listed in [After working inside your system](#).

# System board

A system board (also known as the motherboard) is the main printed circuit board in the system with different connectors used to connect different components or peripherals of the system. A system board provides the electrical connections to the components in the system to communicate.

## Removing the system board

### Prerequisites

**CAUTION:** If you are using the Trusted Platform Module (TPM) with an encryption key, you may be prompted to create a recovery key during program or System Setup. Be sure to create and safely store this recovery key. If you replace this system board, you must supply the recovery key when you restart your system or program before you can access the encrypted data on your drives.

**NOTE:** Ensure that you note the routing of the cables as you remove them from the system board. You must route the cables properly when you replace them to prevent the cables from being pinched or crimped.

- 1 Follow the safety guidelines listed in [Safety instructions](#).
- 2 Follow the procedure listed in [Before working inside your system](#).
- 3 Remove the following components:
  - a [Air shroud](#)
  - b [All expansion cards and risers](#)
  - c [Mini PERC](#)
  - d [vFlash or IDSDM module](#)
  - e [Internal USB key](#)
  - f [Heat sink](#)
  - g [Processor](#)
  - h [Memory modules](#)
  - i [LOM riser](#)

### Steps

- 1 Disconnect all cables from the system board.

**CAUTION:** Take care not to damage the system identification button while removing the system board from the chassis.

**CAUTION:** Do not lift the system board by holding a memory module, processor, or other components.

- 2 Using Phillips #2 screwdriver, remove ten screws securing the system board to the chassis.
- 3 Hold the system board holder, lift the system board, and then slide it toward the front of the chassis.
- 4 Lift the system board out of the chassis.

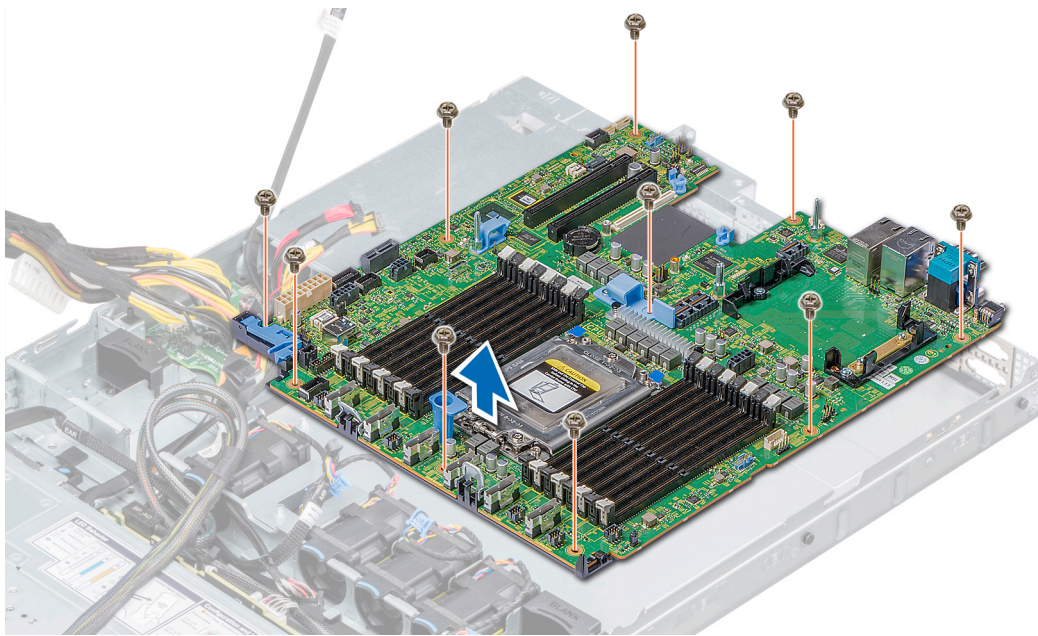

**Figure 94. Removing the system board**

#### **Next step**

Install the system board. for more information, see [Installing the system board](#).

## Installing the system board

#### **Prerequisite**

Follow the safety guidelines listed in [Safety instructions](#).

#### **Steps**

- 1 Unpack the new system board assembly.

**⚠ CAUTION: Do not lift the system board by holding a memory module, processor, or other components.**

**⚠ CAUTION: Take care not to damage the system identification button while placing the system board into the chassis.**

- 2 Holding the system board holder, push the system board toward the back of the system till it is seated.  
Ensure that all the screw holes are aligned over the stand-offs
- 3 Using Phillips #2 screwdriver, tighten the screws to secure the system board to the chassis.

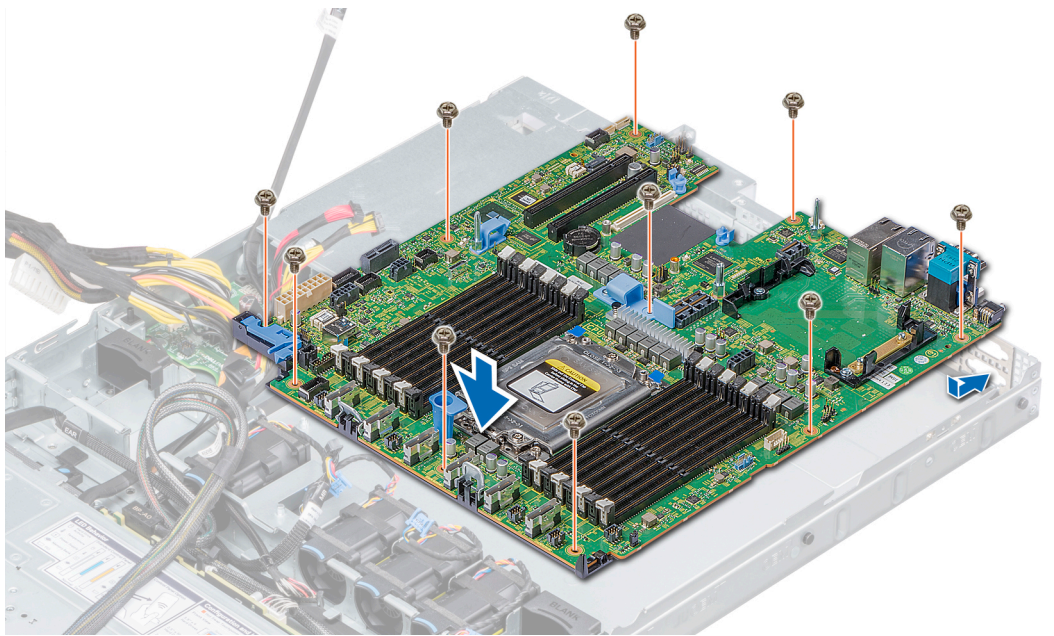

**Figure 95. Installing system board**

### Next steps

- 1 Install the Trusted Platform Module (TPM).
- 2 Replace the following:
  - a [Mini PERC](#)
  - b [Internal USB key \(if applicable\)](#)
  - c [IDSDM or vFlash module card](#)
  - d [All expansion cards and risers](#)
  - e [Processor](#)
  - f [Heat sink](#)
  - g [Memory modules](#)
  - h [LOM riser card](#)
  - i [Air shroud](#)
- 3 Reconnect all cables to the system board.

**NOTE:** Ensure that the cables inside the system are routed along the chassis wall and secured using the cable securing bracket.

- 4 Follow the procedure listed in [After working inside your system](#).
- 5 Ensure that you:
  - a Use the Easy Restore feature to restore the Service Tag. For more information, see the Easy restore section.
  - b If the Service Tag is not backed up in the backup flash device, enter the Service Tag manually. For more information, see the Restoring the Service Tag by using the [Easy Restore](#) feature section.
  - c Update the BIOS and iDRAC versions.
  - d Re-enable the Trusted Platform Module (TPM). For more information, see the Replacing the Trusted Platform Module section.
- 6 Import your new or existing iDRAC Enterprise license.  
For more information, see iDRAC User's Guide, at [Dell.com/idracmanuals](http://Dell.com/idracmanuals).

# Restoring the Service Tag using Easy Restore

The easy restore feature allows you to restore your service tag, license, UEFI configuration, and the system configuration data after replacing the system board. All data is backed up in a backup flash device automatically. If BIOS detects a new system board, and the service tag in the backup flash device, BIOS prompts the user to restore the backup information.

Below is a list of options available:

- Restore the service tag, license, and diagnostics information, press **Y**
- Navigate to the Lifecycle Controller based restore options, press **N**.
- Restore data from a previously created **Hardware Server Profile**, press **F10**

**NOTE:** When the restore process is complete, BIOS prompts to restore the system configuration data.

- To restore the system configuration data, press **Y**
- To use the default configuration settings, press **N**

**NOTE:** After the restore process is complete, system reboots.

## Manually update the Service Tag

After replacing a system board, if Easy Restore fails, follow this process to manually enter the Service Tag, using **System Setup**.

### About this task

If you know the system service tag, use the **System Setup** menu to enter the service tag.

### Steps

- 1 Turn on the system.
- 2 To enter the **System Setup**, press **F2**.
- 3 Click **Service Tag Settings**.
- 4 Enter the service tag.

**NOTE:** You can enter the service tag only when the Service Tag field is empty. Ensure that you enter the correct service tag. Once the service tag is entered, it cannot be updated or changed.

- 5 Click **OK**.

## Trusted Platform Module

Trusted Platform Module (TPM) is a dedicated microprocessor designed to secure hardware by integrating cryptographic keys into devices. Software can use a TPM to authenticate hardware devices. Because each TPM chip has a unique and secret RSA key which is embedded during the manufacture of the TPM, it is capable of performing platform authentication operation.

## Replacing the Trusted Platform Module

### Prerequisites

- 1 Follow the safety guidelines listed in [Safety instructions](#).
- 2 Follow the procedure listed in [Before working inside your system](#).

### NOTE:

- Ensure that your operating system supports the version of the TPM module being installed.
- Ensure that you download and install the latest BIOS firmware on your system.
- Ensure that the BIOS is configured to enable UEFI boot mode.

## Steps

1 Locate the TPM connector on the system board.

**NOTE:** To locate the TPM connector on the system board, see the [System board jumpers and connectors](#) section.

2 Press to hold the module down and remove the screw using the security Torx 8-bit shipped with the TPM module.

3 Slide the TPM module out from its connector.

4 Push the plastic rivet away from the TPM connector and rotate it 90° counterclockwise to release it from the system board.

5 Pull the plastic rivet out of its slot on the system board.

6 To install the TPM, align the edge connectors on the TPM with the slot on the TPM connector.

7 Insert the TPM into the TPM connector such that the plastic rivet aligns with the slot on the system board.

8 Press the plastic rivet until the rivet snaps into place.

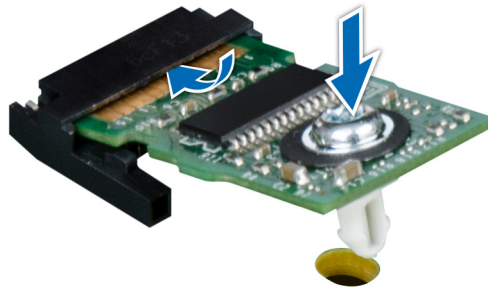

Figure 96. Installing the TPM

## Next steps

1 [Install the system board.](#)

2 Follow the procedure listed in [After working inside your system.](#)

## Initializing TPM for BitLocker users

Initialize the TPM.

For more information, see <http://technet.microsoft.com/en-us/library/cc753140.aspx>.

The **TPM Status** changes to **Enabled, Activated**.

# Using system diagnostics

If you experience a problem with your system, run the system diagnostics before contacting Dell for technical assistance. The purpose of running system diagnostics is to test your system hardware without using additional equipment or risking data loss. If you are unable to fix the problem yourself, service and support personnel can use the diagnostics results to help you solve the problem.

## Dell Embedded System Diagnostics

① **NOTE:** The Dell Embedded System Diagnostics is also known as Enhanced Pre-boot System Assessment (ePSA) diagnostics.

The Embedded System Diagnostics provides a set of options for particular device groups or devices allowing you to:

- Run tests automatically or in an interactive mode
- Repeat tests
- Display or save test results
- Run thorough tests to introduce additional test options to provide extra information about the failed device(s)
- View status messages that inform you if tests are completed successfully
- View error messages that inform you of problems encountered during testing

## Running the Embedded System Diagnostics from Boot Manager

Run the Embedded System Diagnostics (ePSA) if your system does not boot.

- 1 When the system is booting, press F11.
- 2 Use the up arrow and down arrow keys to select **System Utilities > Launch Diagnostics**.
- 3 Alternatively, when the system is booting, press F10, select **Hardware Diagnostics > Run Hardware Diagnostics**.  
The **ePSA Pre-boot System Assessment** window is displayed, listing all devices detected in the system. The diagnostics starts executing the tests on all the detected devices.

## Running the Embedded System Diagnostics from the Dell Lifecycle Controller

- 1 As the system boots, press F10.
- 2 Select **Hardware Diagnostics → Run Hardware Diagnostics**.  
The **ePSA Pre-boot System Assessment** window is displayed, listing all devices detected in the system. The diagnostics starts executing the tests on all the detected devices.

## System diagnostic controls

Menu	Description
<b>Configuration</b>	Displays the configuration and status information of all detected devices.
<b>Results</b>	Displays the results of all tests that are run.
<b>System health</b>	Provides the current overview of the system performance.
<b>Event log</b>	Displays a time-stamped log of the results of all tests run on the system. This is displayed if at least one event description is recorded.

# Jumpers and connectors

This topic provides specific information about the jumpers. It also provides some basic information about jumpers and switches and describes the connectors on the various boards in the system. Jumpers on the system board help to disable the system and setup passwords. You must know the connectors on the system board to install components and cables correctly.

## Topics:

- [System board jumpers and connectors](#)
- [System board jumper settings](#)
- [Disabling forgotten password](#)

# System board jumpers and connectors

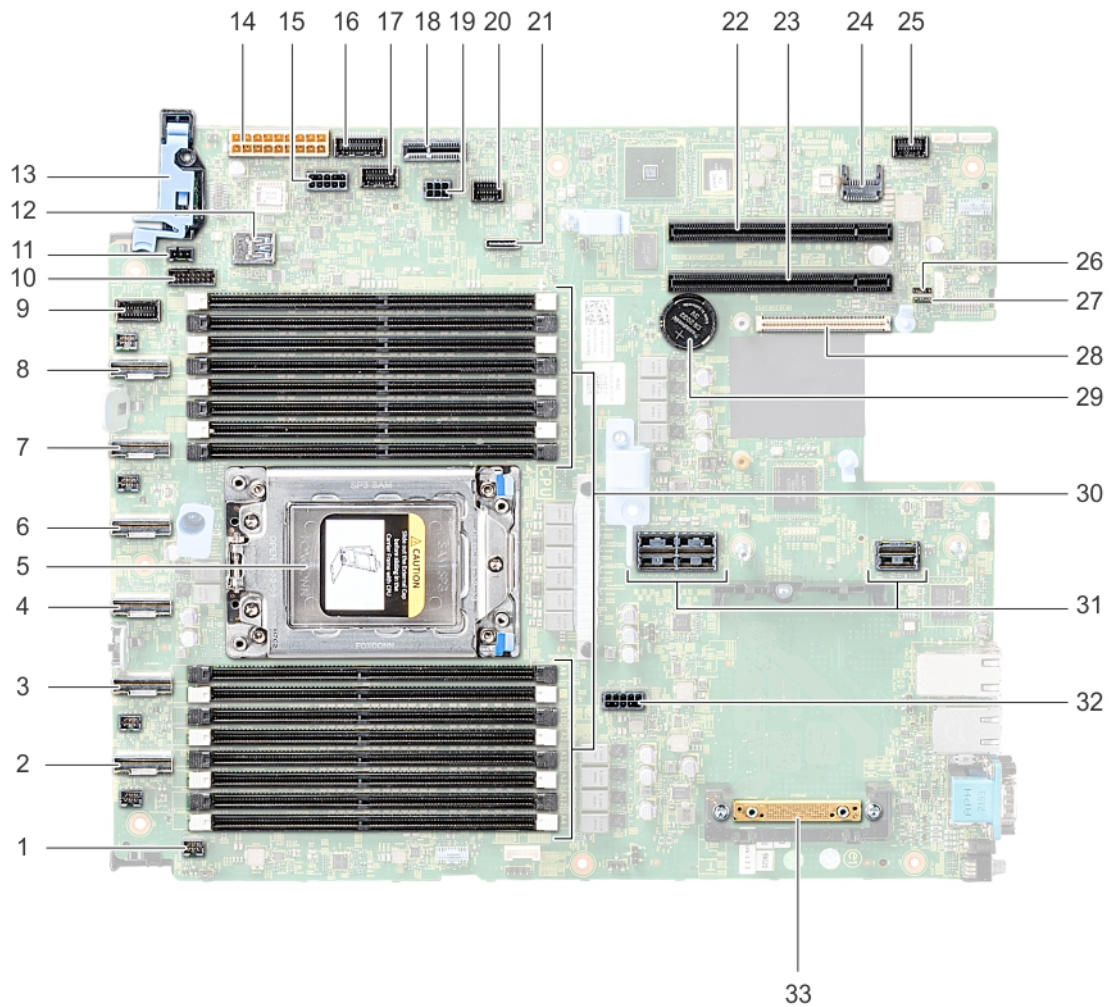

Figure 97. System board jumpers and connectors

Table 46. System board jumpers and connectors



Item	Connector	Description
1.	FAN6	Cooling fan 6 connector
2.	SATA_A/PCIE_A	Internal SATA A connector
3.	PCIE_B	PCIe B connector
4.	SATA_B/PCIE_B	Internal SATA B connector
5.	CPU	Processor socket
6.	PCIE_D	PCIe D connector
7.	PCIE_E	PCIe E connector
8.	PCIE_F	PCIe F connector



Item	Connector	Description
9.	LFT_CP_CONN	Left control panel connector
10.	BP_SIG1	Backplane signal connector 1
11.	INTRUSION	Intrusion switch connector
12.	J_USB3_INT1	USB connector
13.	RGT_CP_CONN	Right control panel connector
14.	SYS_PWR1	System power connector 1
15.	SYS_PWR2	System power connector 2
16.	PIB_SIG2	Power interposer board signal connector 2
17.	PIB_SIG1	Power interposer board signal connector 1
18.	IDSDM	Internal Dual SD Module connector
19.	J_BP_PWR0	Backplane power connector
20.	J_BP_SIG0	Backplane signal connector
21.	J_SATA_A1	SATA A connector
22.	SLOT5	PCIe slot 5
23.	SLOT4	PCIe slot 4
24.	J_TPM_MODULE	TPM module connector
25.	J_FRONT_VIDEO01	VGA connector
26.	PWRD_EN	Reset BIOS password
27.	NVRAM_CLR	Clear NVRAM
28.	SLOT1	LOM riser card connector
29.	BATTERY	Battery connector
30.	A8, A16, A7, A15, A6, A14, A5, A13, A9, A1, A10, A2, A11, A3, A12, A4	Memory module sockets
31.	RISER1A/RISER1B	Expansion card riser connector [2U riser]
32.	SYS_PWR3	System power connector 3
33.	J_STORAGE	Mini PERC card connector

## System board jumper settings

For information on resetting the password jumper to disable a password, see the Disabling a forgotten password section.

**Table 47. System board jumper settings**

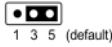
Jumper	Setting	Description
PWRD_EN	 (default)	The BIOS password feature is enabled.
		The BIOS password feature is disabled. iDRAC local access is unlocked at next AC power cycle. iDRAC password reset is enabled in F2 iDRAC settings menu.

Jumper	Setting	Description
NVRAM_CLR	 1 3 5 (default)	The BIOS configuration settings are retained at system boot.
	 1 3 5	The BIOS configuration settings are cleared at system boot.

## Disabling forgotten password

The software security features of the system include a system password and a setup password. The password jumper enables or disables password features and clears any password(s) currently in use.

### Prerequisite

**CAUTION:** Many repairs may only be done by a certified service technician. You should only perform troubleshooting and simple repairs as authorized in your product documentation, or as directed by the online or telephone service and support team. Damage due to servicing that is not authorized by Dell is not covered by your warranty. Read and follow the safety instructions that are shipped with your product.

### Steps

- 1 Turn off the system, including any attached peripherals, and disconnect the system from the electrical outlet.
- 2 Remove the system cover.
- 3 Move the jumper on the system board jumper from pins 2 and 4 to pins 4 and 6.
- 4 Install the system cover.

The existing passwords are not disabled (erased) until the system boots with the jumper on pins 4 and 6. However, before you assign a new system and/or setup password, you must move the jumper back to pins 2 and 4.

**NOTE:** If you assign a new system and/or setup password with the jumper on pins 4 and 6, the system disables the new password(s) the next time it boots.

- 5 Reconnect the system to its electrical outlet and turn on the system, including any attached peripherals.
- 6 Turn off the system, including any attached peripherals, and disconnect the system from the electrical outlet.
- 7 Remove the system cover.
- 8 Move the jumper on the system board jumper from pins 4 and 6 to pins 2 and 4.
- 9 Install the system cover.
- 10 Reconnect the system to its electrical outlet and turn on the system, including any attached peripherals.
- 11 Assign a new system and/or setup password.

# Getting help

Topics:

- [Contacting Dell](#)
- [Documentation feedback](#)
- [Accessing system information by using QRL](#)
- [Receiving automated support with SupportAssist](#)

## Contacting Dell

Dell provides several online and telephone based support and service options. If you do not have an active internet connection, you can find contact information about your purchase invoice, packing slip, bill, or Dell product catalog. Availability varies by country and product, and some services may not be available in your area. To contact Dell for sales, technical assistance, or customer service issues:

- 1 Go to [Dell.com/support](https://Dell.com/support).
- 2 Select your country from the drop-down menu on the lower right corner of the page.
- 3 For customized support:
  - a Enter your system Service Tag in the **Enter your Service Tag** field.
  - b Click **Submit**.The support page that lists the various support categories is displayed.
- 4 For general support:
  - a Select your product category.
  - b Select your product segment.
  - c Select your product.The support page that lists the various support categories is displayed.
- 5 For contact details of Dell Global Technical Support:
  - a Click [Global Technical Support](#).
  - b The **Contact Technical Support** page is displayed with details to call, chat, or e-mail the Dell Global Technical Support team.

## Documentation feedback

You can rate the documentation or write your feedback on any of our Dell documentation pages and click **Send Feedback** to send your feedback.

## Accessing system information by using QRL

You can use the Quick Resource Locator (QRL) to get immediate access to the information about your system.

### Prerequisites

Ensure that your smartphone or tablet has the QR code scanner installed.

The QRL includes the following information about your system:

- How-to videos
- Reference materials, including the Owner's Manual, LCD diagnostics, and mechanical overview

- Your system service tag to quickly access your specific hardware configuration and warranty information
- A direct link to Dell to contact technical assistance and sales teams

### Steps

- 1 Go to [Dell.com/QRL](https://Dell.com/QRL) and navigate to your specific product or
- 2 Use your smartphone or tablet to scan the model-specific Quick Resource (QR) code on your Dell PowerEdge system or in the Quick Resource Locator section.

## Quick Resource Locator for R6415

### Quick Resource Locator for PowerEdge R6415



Figure 98. Quick Resource Locator for R6415

## Receiving automated support with SupportAssist

Dell SupportAssist is an optional Dell Services offering that automates technical support for your Dell server, storage, and networking devices. By installing and setting up a SupportAssist application in your IT environment, you can receive the following benefits:

- **Automated issue detection** — SupportAssist monitors your Dell devices and automatically detects hardware issues, both proactively and predictively.
- **Automated case creation** — When an issue is detected, SupportAssist automatically opens a support case with Dell Technical Support.
- **Automated diagnostic collection** — SupportAssist automatically collects system state information from your devices and uploads it securely to Dell. This information is used by Dell Technical Support to troubleshoot the issue.
- **Proactive contact** — A Dell Technical Support agent contacts you about the support case and helps you resolve the issue.

The available benefits vary depending on the Dell Service entitlement purchased for your device. For more information about SupportAssist, go to [Dell.com/SupportAssist](https://Dell.com/SupportAssist).